

SCHOOL BOARD OF ALACHUA COUNTY, FLORIDA SUBMIT BID TO: <i>See Bid mailing instructions on page 2</i>	INVITATION FOR BID Bidder Acknowledgement and Acceptance Form
BID TITLE: BHS STORMWATER DRAINAGE IMPROVEMENTS	BID NO. 24-55
DELIVERY F.O.B. DESTINATION: Buchholz High School, 5510 NW 27th Ave, Gainesville, FL 32606	ISSUE DATE: April 10, 2024 PURCHASING DEPARTMENT PHONE/FAX # (352) 955-7582 / (844) 269-9018
BID DUE DATE AND TIME: <u>April 26, 2024 @ 3:00 PM EST</u>	BID OPENING: Purchasing Department

A pre-bid meeting is scheduled for **April 17, 2024 at 9:30am at Buchholz High School, 5510 NW 27th Ave, Gainesville, FL 32606.**
This is a **mandatory meeting**. Bids submitted by Bidders not in attendance at this meeting will not be accepted by the Purchasing Department.

The undersigned ("Bidder") hereby submits the following offer and attests that it understands, agrees to, and will abide by all terms, conditions, specifications, and instructions contained in the Invitation For Bid ("IFB"), inclusive of the contents of any Addenda hereto. Bidder agrees to be bound by a contract, the form of which will be provided by the School Board of Alachua County, to provide the materials and/or services described in this IFB. Further, Bidder attests that it has not divulged, discussed, or compared this offer with any other Bidder and has not colluded with any other Bidder in the preparation of this offer in order to gain an unfair advantage in the award of the pending contract. Finally, Bidder acknowledges that all information contained herein is subject to the Public Records Act, Chapter 119, F.S.

BIDDER NAME:

SIGNATURE OF OWNER OR
AUTHORIZED OFFICER/AGENT:

TYPED TITLE:

BIDDER MAILING ADDRESS:

AREA CODE/PHONE #

FAX #:

BIDDER EMAIL ADDRESS:

BIDDER WEB ADDRESS:

DATE:

EIN/FEDERAL TAX ID#:

PROOF OF E-VERIFY PARTICIPATION ENCLOSED (REF. ATTACHMENT A, ITEM 76): YES NO

SBAC personnel may choose to use a Visa™ purchasing card in place of a purchase order to make purchases under this IFB. Unless exception to this condition is checked below, Bidder, by submitting a Bid, agrees to accept the purchasing card as an acceptable form of payment and may not add additional service fees or handling charges to purchases made under this IFB using the purchasing card.

NO BID THE PROSPECTIVE BIDDER HEREBY SUBMITS A "NO BID" FOR THE REASON(S) NOTED BELOW:

- | | |
|---|--|
| <input type="checkbox"/> 1. Insufficient time to respond to the IFB | <input type="checkbox"/> 4. Our production/service schedule will not permit a response |
| <input type="checkbox"/> 2. Could not meet the specifications | <input type="checkbox"/> 5. Remove our name from this bid list only |
| <input type="checkbox"/> 3. Does not offer the product or service specified | <input type="checkbox"/> 6. Other _____ |

FAX THIS "NO BID" FORM TO (844) 269-9018. INCLUDE THE COMPANY INFORMATION REQUESTED ABOVE. FAILURE TO SUBMIT THIS FORM MAY RESULT IN BIDDER'S REMOVAL FROM SBAC'S ACTIVE BIDDERS LIST.

USE OF FEDERAL FUNDS: If SBAC intends to utilize Federal funds to make purchases using the contract formed as a result of this IFB, then one or more of the paragraphs listed below (ref. Attachment A, General Conditions, Instructions to Bidders) will be checked. Paragraphs not checked below do not apply to this IFB.

- Paragraph 66 Paragraph 67 Paragraph 68 Paragraph 69 Paragraph 70 Paragraph 71 Paragraph 72 Paragraph 73
 Paragraph 74

ADDITIONAL INFORMATION REGARDING THE SCHOOL BOARD OF ALACHUA COUNTY, INCLUDING SCHOOL AND DEPARTMENT ADDRESSES AND THE CURRENT SCHOOL YEAR CALENDAR, IS LOCATED AT WWW.SBAC.EDU. THE PURCHASING DEPARTMENT'S HOME PAGE IS ALSO LOCATED ON THIS WEB SITE AND INCLUDES ALL CURRENT BID OPPORTUNITES AND INFORMATION ON AWARDED CONTRACTS.

Bidder's sealed Bid must be received in the Purchasing Department on or before the date and time specified above.

If sent via US Mail or express delivery carrier (UPS, FedEx, DHL, etc.), address Bid to:

<p>School Board of Alachua County District Office Attn: Purchasing Department 620 East University Avenue Gainesville, FL 32601</p>

If delivered by hand, deliver Bid to the Purchasing Department located on second floor (Room 02-212) of District Administration Building at above address. Upon arrival at facility, sufficient time should be allowed to check-in at reception desk and arrive at Purchasing Department. Bids received by telephone, email, or facsimile transmission will be considered non-responsive.

Bids received after the specified date and time are late and will not be considered for award. Late Bids will be returned unopened to the Bidder. The responsibility for delivering Bids to the School Board of Alachua County Purchasing Department on or before the specified time and date is solely and strictly the responsibility of the Bidder. Bids delivered to any other School Board Department, School, or other administrative site will not be accepted. The official Purchasing Department time/date stamp clock will be used to determine on what date and at what time a Bid is received.

At this time a public opening of Bids received will be held. At a regularly scheduled meeting of the Board, the Bids as so opened, tabulated and evaluated as prescribed, and with the recommendation of the Superintendent of Schools of this county regarding them, shall be presented to the Board for its consideration. Any Bid accepted or contract awarded shall be to the low responsive and responsible Bidder meeting the requirements of law, State Board of Education rules, School Board policies, and the requirements set forth in this IFB.

Bid Package: Mark in lower left-hand corner of the outermost envelope/parcel box containing your Bid, **“IFB #24-55, BHS STORMWATER DRAINAGE IMPROVEMENTS”, TO BE OPENED AT 3:00 P.M., APRIL 26, 2024.** Mark your company name and address on upper left-hand corner of the envelope. Bids will not be considered unless prepared in ink or typewritten and signed in ink. Sales tax is only applied to materials purchased directly by a prospective Bidder. In all other respects, the School Board of Alachua County is tax exempt.

This IFB, including the General Conditions, Instructions to Bidders–Supplies/Services, any Addenda issued hereto, and the following documents form a part of each Bidder's offer and by reference are made a part thereof:

- BIDDER ACKNOWLEDGEMENT AND ACCEPTANCE FORM
- SUBMITTALS CHECKLIST FORM
- CERTIFICATION REGARDING DEBARMENT, SUSPENSION, INELIGIBILITY AND VOLUNTARY EXCLUSION – LOWER TIER COVERED TRANSACTIONS
- JESSICA LUNSFORD ACT – BIDDER AFFIRMATION FORM
- SMALL/MINORITY BUSINESS ENTERPRISE FORM
- INSURANCE CERTIFICATION FORM
- ATTACHMENT A - GENERAL CONDITIONS, INSTRUCTIONS TO BIDDERS – SUPPLIES/SERVICES
- ATTACHMENT B – GENERAL/TECHNICAL SPECIFICATIONS
- ATTACHMENT C- FORM OF PROPOSAL AND BIDDER QUESTIONNAIRE
- APPENDIX A – CONSTRUCTION PLANS FOR BUCHHOLZ HIGH SCHOOL BATTING CAGE DRAINAGE IMPROVEMENTS

SUBMITTALS CHECKLIST

This checklist serves to provide the Bidder with a tool to ensure that its Bid contains all required submittals. Bidder shall each box in the “Verified” column to indicate that the item is included in its Bid. Bidder shall then include the completed checklist in its Bid.

Bidder shall submit one (1) original copy of Bid response only in the following order as indicated below. It is not necessary to return a copy of issued Bid in its entirety.

Verified	Submittal Description	Page Reference
<input type="checkbox"/>	Bidder Acknowledgement and Acceptance Form	1
<input type="checkbox"/>	Proof of E-Verify Participation Enclosed (see Attachment A, Item 76)	1
<input type="checkbox"/>	Debarment Form	5
<input type="checkbox"/>	Jessica Lunsford Act Form	6
<input type="checkbox"/>	Small/Minority Business Enterprise Form	7
<input type="checkbox"/>	Insurance Certification Form	9
<input type="checkbox"/>	Attachment C – Form of Proposal	28
<input type="checkbox"/>	Bidder Questionnaire	29
<input type="checkbox"/>	References	30-31
<input type="checkbox"/>		

REMEMBER TO CHECK THE PURCHASING WEBSITE FOR ANY ADDENDA THAT MAY HAVE BEEN ISSUED (www.sbac.edu)

FAILURE TO SUBMIT ALL INFORMATION AS REQUESTED WITH BID RESPONSE MAY CAUSE BID TO BE DECLARED NON-RESPONSIVE.

**Certification Regarding Debarment, Suspension, Ineligibility and
Voluntary Exclusion – Lower Tier Covered Transactions**

This certification is required by the Department of Education regulations implementing Executive Order 12549, Debarment and Suspension, 34 CFR Part 85, for all lower tier transactions meeting the threshold and tier requirements stated at Section 84.110.

Instructions for Certification

1. By signing and submitting the proposal, the prospective lower tier participant is providing the certification set out below.
2. The certification in this clause is a material representation of fact upon which reliance was placed when this transaction was entered into. If it is later determined that the prospective lower tier participant knowingly rendered an erroneous certification, in addition to other remedies available to the Federal Government, the department or agency with which this transaction originated may pursue available remedies, including suspension and/or debarment.
3. The prospective lower tier participant shall provide immediate written notice to the person to which this proposal is submitted if at any time the prospective lower tier participant learns that its certification was erroneous when submitted or has become erroneous by reason of changed circumstances.
4. The terms "covered transaction," "debarred," "suspended," "ineligible," "lower tier covered transaction," "participant," "person," "primary covered transaction," "principal," "proposal," and "voluntarily excluded," as used in this clause, have the meanings set out in the Definitions and Coverage sections of rules implementing Executive Order 12549. You may contact the person to which this proposal is submitted for assistance in obtaining a copy of those regulations.
5. The prospective lower tier participant agrees by submitting this proposal that, should the proposed covered transaction be entered into, it shall not knowingly enter into any lower tier covered transaction with a person who is debarred, suspended, declared ineligible, or voluntarily excluded from participation in this covered transaction, unless authorized by the department or agency with which this transaction originated.
6. The prospective lower tier participant further agrees by submitting this proposal that it will include the clause titled "Certification Regarding Debarment, Suspension, Ineligibility, and Voluntary Exclusion-Lower Tier Covered Transactions," without modification, in all lower tier covered transactions and in all solicitations for lower tier covered transactions.
7. A participant in a covered transaction may rely upon a certification of a prospective participant in a lower tier covered transaction that it is not debarred, suspended, ineligible, or voluntarily excluded from the covered transaction, unless it knows that the certification is erroneous. A participant may decide the method and frequency by which it determines the eligibility of its principals. Each participant may but is not required to, check the Nonprocurement List.
8. Nothing contained in the foregoing shall be construed to require establishment of a system of records in order to render in good faith the certification required by this clause. The knowledge and information of a participant is not required to exceed that which is normally possessed by a prudent person in the ordinary course of business dealings.
9. Except for transactions authorized under paragraph 5 of these instructions, if a participant in a covered transaction knowingly enters into a lower tier covered transaction with a person who is suspended, debarred, ineligible, or voluntarily excluded from participation in this transaction, in addition to other remedies available to the Federal Government, the department or agency with which this transaction originated may pursue available remedies, including suspension and/or debarment.

Certification

- (1) The prospective lower tier participant certifies, by submission of this proposal, that neither it nor its principals are presently debarred, suspended, proposed for debarment, declared ineligible, or voluntarily excluded from participation in this transaction by any Federal department or agency.
- (2) Where the prospective lower tier participant is unable to certify to any of the statements in this certification, such prospective participants shall attach an explanation to this proposal.

NAME OF APPLICANT	PR/AWARD NUMBER AND/OR PROJECT NAME
IFB #24-55 – BHS STORMWATER DRAINAGE IMPROVEMENTS	
PRINTED NAME AND TITLE OF AUTHORIZED REPRESENTATIVE	
SIGNATURE	DATE

JESSICA LUNSFORD ACT – BIDDER AFFIRMATION FORM

The School Board is required to conduct background screening of Bidders (including its employees, agents, and sub-contractors) that are contracted with the School Board (go to www.sbac.edu for finger printing and Level 2 screening procedures). Background screening includes submission of Bidder’s fingerprints to the FDLE and FBI. The standards for screening depend on the nature of the work to be performed by Bidder.

- A. If Bidder’s performance either **is** anticipated to result in direct contact with students, or will give Bidder access to or control of school funds, then the screening standard is that Bidder may not have been convicted of a crime involving moral turpitude. The School Board has defined “crimes involving moral turpitude” to include, but not be limited to the following: felony sexual-related crimes, felony child abuse crimes, murder, lewd and lascivious crimes, and indecent exposure (if sexual in nature).
- B. If Bidder’s performance **is not** anticipated to result in direct contact with students, then the screening standard is that Bidder may not have been convicted of any of the following offenses: Any offense listed in s. [943.0435](#)(1)(a)1., relating to the registration of an individual as a sexual offender; Section [393.135](#), relating to sexual misconduct with certain developmentally disabled clients and the reporting of such sexual misconduct; Section [394.4593](#), relating to sexual misconduct with certain mental health patients and the reporting of such sexual misconduct; Section [775.30](#), relating to terrorism; Section [782.04](#), relating to murder; Section [787.01](#), relating to kidnapping; Any offense under chapter 800, relating to lewdness and indecent exposure; Section [826.04](#), relating to incest; Section [827.03](#), relating to child abuse, aggravated child abuse, or neglect of a child.

"Convicted" means that there has been a determination of guilt as a result of a trial or the entry of a plea of guilty or nolo contendere, regardless of whether adjudication is withheld. Conviction of a similar offense includes, but is not limited to, a conviction by a federal or military tribunal, including courts-martial conducted by the Armed Forces of the United States, and includes a conviction or entry of a plea of guilty or nolo contendere resulting in a sanction in any state of the United States or other jurisdiction. A sanction includes, but is not limited to, a fine, probation, community control, parole, conditional release, control release, or incarceration in a state prison, federal prison, private correctional facility, or local detention facility.

Exemptions from fingerprint based background screening: If Bidder’s work is non-instructional in nature, then Bidder may be exempt from the background screening requirements above if Bidder meets one of the following criteria: **1)** Bidder is under the direct supervision of a School Board employee or contractor or one or more Bidder employees who have had a criminal history check and meet the screening requirements under s. 1012.32, s. 1012.465, s. 1012.467, or s. 1012.56. "Direct supervision" means that a School Board employee or contractor or one or more Bidder employees is physically present with Bidder when Bidder has access to a student and the access remains in the School Board employee's or the contractor's or one or more Bidder employees’ line of sight; **2)** Bidder is required by law to undergo a level 2 background screening pursuant to s. 435.04 for licensure, certification, employment, or other purposes and Bidder submits evidence of meeting the following criteria: a) Bidder meets the screening standards in s. 435.04, b) Bidder’s license or certificate is active and in good standing, if Bidder is a licensee or certificate-holder, c) Bidder has completed the criminal history check within 5 years prior to seeking access to school grounds when students are present; **3)** Bidder is a law enforcement officer, as defined in s. 943.10, who is assigned or dispatched to school grounds by Bidder’s employer; **4)** Bidder is an employee or medical director of an ambulance provider, licensed pursuant to chapter 401, who is providing medical transportation services; **5)** Bidder remains at a site where students are not permitted and the site is separated from the remainder of the school grounds by a single chain-link fence of 6 feet in height; **6)** Bidder provides pick-up or delivery services and those services involve brief visits on school grounds when students are present.

However, even if Bidder is an exempt as defined above, Bidder will be subject to a search of Bidder’s name against the registration information regarding sexual predators and sexual offenders maintained by the FDLE under s. 943.043 and the national sex offender public registry maintained by the U.S. Department of Justice. There is no charge for this search.

Certification

By submitting a Bid in response to this IFB, Bidder swears and affirms under penalty of perjury that all of its employees, agents, and sub-contractors will comply with this form, the requirements of the Jessica Lunsford Act, SBAC’s fingerprinting procedures, and the laws of the State of Florida. Failure to comply with this form, the Jessica Lunsford Act, SBAC’s fingerprinting procedures, and the laws of the State of Florida shall constitute a material breach of the contract, and SBAC may avail itself of all remedies pursuant to law. Bidder agrees to indemnify and hold harmless the School Board, its officers, employees, and agents, from and against any and all claims or causes of action, including without limitation those for personal injury, death, property damages, and attorney fees, arising out of or relating to Bidder's failure to comply with this form, the Jessica Lunsford Act, SBAC’s fingerprinting procedures, and the laws of the State of Florida.

NAME OF BIDDER	BID # AND TITLE
IFB #24-55 – BHS STORMWATER DRAINAGE IMPROVEMENTS	
PRINTED NAME AND TITLE OF AUTHORIZED REPRESENTATIVE	
SIGNATURE	DATE

SMALL/MINORITY BUSINESS ENTERPRISE CERTIFICATION FORM

If applicable¹, Bidder represents that it is either a

Small Business Enterprise, as defined in FS 288.703(6),

or a

Minority Business Enterprise,

Please circle one or more as applicable

- | | |
|------------------|-------------------|
| African-American | Hispanic American |
| Asian American | Native American |
| American Women | |

as defined in FS 288.703 (2) and (3), and that it has been certified by one of the following agencies as an MBE:

- State of Florida, Department of Management Services, Office of Supplier Diversity
- City of Gainesville Florida Small Business Procurement Program
- Alachua County Florida Equal Opportunity Division

What is the expiration date on your MBE certificate: _____

If you are not a small or minority business enterprise, but intend to subcontract a portion of the services or work described in this IFB to a small or minority business enterprise, please provide the following information:

	<u>Subcontractor Name</u>	<u>Small/MBE Designation (see above)</u>	<u>Estimated Dollar Value of Services</u>
1.	_____	_____	_____
2.	_____	_____	_____
3.	_____	_____	_____

NAME OF BIDDER	BID # AND TITLE
IFB #24-55 – BHS STORMWATER DRAINAGE IMPROVEMENTS	
PRINTED NAME AND TITLE OF AUTHORIZED REPRESENTATIVE	
SIGNATURE	DATE

¹ If Bidder is not a small or minority business enterprise and does not intend to subcontract a portion of the services or work described in this IFB to a S/MBE, then Bidder shall not execute this form.

INSURANCE CERTIFICATION FORM

This form is applicable is not applicable to the IFB.

Bidder shall, at Bidder's sole expense, procure and maintain during the term of the Contract, at least the following minimum insurance coverage, which shall not limit the liability of the Bidder:

Applicable Not Applicable

Workers Compensation – Coverage A

- **Statutory**
- **An exemption certificate from the State will be required if Bidder claims exemption from Workers Compensation Insurance**

Comprehensive General Liability

- **\$1,000,000 Each Occurrence**
- **\$1,000,000 Per Project Aggregate**
- **\$1,000,000 Products and Completed Operations Aggregate**
- **Premises Operations**
- **Blanket Contractual Liability**
- **Personal Injury Liability**
- **Expanded Definition of Property Damage**

Comprehensive Automobile Liability (Combined Single Limit)

- **\$1,000,000 Each Occurrence**

Applicable Not Applicable **Professional Liability Insurance - \$1,000,000 Each Occurrence**

Applicable Not Applicable **Pollution Liability Insurance - \$1,000,000 Each Occurrence**

Applicable Not Applicable **Umbrella/Excess Liability Insurance- \$1,000,000 Each Occurrence**

All policies of insurance shall be rated "A" or better by the most recently published A.M. Best Rating Guide and shall be subject to SBAC approval as to form and issuing company. SBAC shall be named as an *additional insured* in the comprehensive general (including property damage) liability policy within five (5) calendar days prior to Board action on the recommended contract award. Bidder shall furnish SBAC copies of insurance certificates evidencing that it maintains at least the insurance coverage required hereunder, and which contain the following or equivalent clause: *"Before any reduction, cancellation, modification or expiration of the insurance policy, thirty (30) days prior written notice thereof shall be given to SBAC."* **Bidder is NOT authorized to proceed with the services until all the insurance certificates have been received and accepted.** Receipt of certificates or other documentation of insurance or policies or copies of policies by SBAC, or by any of its representatives, which indicate less coverage than required does not constitute a waiver of the Bidder's obligation to fulfill the insurance requirements herein.

By signing this form, Bidder warrants and represents that it will provide the insurance coverage described above and acknowledges that SBAC is relying on the warranties and representations made by Bidder. If selected for contact award, Bidder shall submit the Certificate of Insurance prescribed above on Accord form 25 no later than five (5) calendar days prior to Board action on the recommended award. The Certificate of Insurance shall be sent to the Purchasing Department (By mail or express delivery to: 620 East University Avenue, Gainesville Florida, 32601; by hand to: Purchasing Department located on second floor (Room 02-212) of the District Administration Building at above address; by facsimile transmission to: 844.269.9018).

Company Name: _____ Date: _____

Authorized Signature: _____

Printed Name: _____ Title: _____

Inquiries regarding Bidder's insurance coverage and certificates should be addressed to:

Printed Name: _____ Title: _____

Phone #: _____ Fax #: _____

Email: _____

ATTACHMENT A

GENERAL CONDITIONS, INSTRUCTIONS TO BIDDERS – SUPPLIES/SERVICES

1. DEFINITIONS:

Invitation for Bids (IFB)-a formal request to prospective vendors soliciting bids, which contains the specifications or scope of services and all contractual terms and conditions.

Bid-an offer submitted by a prospective vendor in response to an invitation for bid (IFB).

Offer-a response to an IFB that, if accepted, would bind the vendor making the offer to perform the resulting Contract.

Bidder- an individual, firm, association, joint venture, partnership, syndicate, corporation, or group that submits a Bid in response to an IFB.

Responsive Bidder-a vendor who has submitted a Bid that conforms in all material respects to the requirements stated in the IFB.

Responsible Bidder-a Bidder who has the capability in all respects to perform fully the Contract requirements, and the experience, integrity, reliability, capacity, facilities, equipment, and credit that will assure good faith performance.

Lowest Responsible Bidder-the Bidder that submitted a responsive Bid at the lowest price of all the responsive Bids submitted, and whose past performance and financial capability is deemed acceptable.

Alternate Bid-a sealed Bid that intentionally deviates from the IFB specifications and is submitted by a Bidder for consideration by SBAC (see below).

Contract-The submission of a Bid constitutes an offer by the Bidder. Upon acceptance by School Board of Alachua County ("SBAC"), the Purchasing Department will issue a purchase order(s) for supplies, equipment, and/or services pursuant to the IFB. The Bidder's offer, the IFB document, and the corresponding purchase order(s) constitute the complete agreement between the successful Bidder and SBAC. Unless otherwise stipulated in the IFB documents, no other contract documents shall be issued or accepted.

2. ORDER OF PRECEDENCE: In the event of any inconsistency between Attachment A and the other documents that together comprise this IFB, such inconsistency will be resolved by giving precedence in the following order: (a) specifications or scope of services; (b) drawings; (c) special conditions; (d) Attachment A; (e) other documents, exhibits, and attachments; (f) the Purchase Order(s).

3. GENERAL BIDDERS INFORMATION: Interested Bidders are advised that SBAC will not, unless specified elsewhere in the IFB document, consider Bids that contain an escalation clause, nor may a successful Bidder seek an increase in price of the items awarded to them under this Bid.

It is understood that normal Bid processing time will be 30 - 60 days after the Bid opening date and that Bid prices will be firm through Bid processing time and delivery of items awarded via Purchase Order.

SBAC reserves the right in its sole discretion to waive any irregularities or minor technicalities in Bids received, reject any or all Bids, accept any part thereof, award to other than the low Bidder, award in the best interest of the SBAC, or cancel the IFB at its discretion.

A signed Bid shall be considered an Offer on the part of the Bidder, which Offer shall be deemed accepted upon approval by SBAC. In the event of a default by the Bidder after such acceptance, SBAC may take such action as it deems appropriate including legal action for damages or specific performance.

The successful Bidder shall give first priority to SBAC in the event of a hurricane, flood, or other natural disaster, or any event identified as an emergency by SBAC.

4. BID OPENING: Shall be public at the time and date specified elsewhere in this IFB. It is the Bidder's responsibility to ensure that the Bid is delivered at the proper time and place. Bids received after the date and time specified in the IFB will be returned to the Bidder unopened. Bids received by telephone, telegraph or facsimile transmission will be considered non-responsive.

5. AWARD: SBAC will award a Contract to the lowest responsive and responsible Bidder.

SBAC reserves the right to make award(s) on an individual, multiple, lump sum or low total basis. See also Item 62 below.

6. WORK CONDITIONS/IFB EXAMINATION: Bidders shall become familiar with any work conditions that may, in any manner, affect the work to be performed under the Contract and shall thoroughly examine and be familiar with the IFB requirements. The failure or omission of any Bidder to become familiar with local work conditions or to examine the IFB shall in no way relieve it of its obligations with respect to the IFB or the subsequent Contract.

7. SILENCE OF THE SPECIFICATIONS: The apparent silence of the IFB specifications as to any detail, or the omission from the specifications of a detailed description, concerning any point shall be construed as meaning that only the best commercial practices are to prevail and that only materials of the highest quality and correct type, size, and design are to be used. All interpretations of the specifications shall be made on the basis of this statement.

8. ADDITIONAL TERMS AND CONDITIONS: No additional terms and conditions included with any Bid shall be evaluated or considered and any and all such additional terms and conditions shall have no force and effect and are inapplicable to this IFB, whether submitted purposefully through intent or design or inadvertently appearing separately in transmittal letters, specifications, literature, price lists, warranties, or shipping documents. It is understood and agreed that only the terms, conditions, and specifications appearing in this IFB are applicable and in full force and effect. The Bidder's authorized signature appearing elsewhere in the IFB attests to this.

9. MANUFACTURER'S NAME AND "OR EQUAL" PRODUCTS: Unless expressly stated otherwise in the IFB, manufacturer's names, trade names, brand names, and catalog numbers listed in the specifications are for the purpose of establishing minimum acceptable levels of quality required by SBAC, and are not intended to limit competition. Unless expressly stated otherwise in the IFB, Bidders may offer any "or equal" product that meets or exceeds the specifications for any items contained herein. For "or equal" Bids, Bidders shall indicate on the Form of Proposal the manufacturer's name and product number proposed. Bidders shall submit with their Bids detailed information (cut sheets, product literature, diagrams, drawings, specifications, etc.) sufficient to allow SBAC to determine whether in fact the proposed "or equal" product(s) meets or exceeds SBAC's minimum requirements, as reflected in the specifications. It is the Bidder's responsibility to submit proof that the proposed "or equal" product does in fact meet or exceed the specifications.

This responsibility does not rest with SBAC. SBAC reserves the right in its sole discretion to determine whether or not the proposed "or equal" product(s) complies or does not comply with the minimum specification requirements. Bids that do not meet or exceed the requirements of the specifications will be deemed non-responsive and will not be further considered for award. If a Bidder fails to note the manufacturer and model number on the Form of Proposal, it will be assumed that it is bidding on the specified product(s).

SBAC reserves the right to request from Bidders separate manufacturer certification of all statements made in the Bids.

10. TIE BIDS: shall be resolved in accordance with Board Policy 6320, section titled "Identical Low Bids."
11. FORM: Bids must be typed or printed in ink on the form contained in or prescribed by the IFB and shall bear the original signature and name of the company employee authorized to execute Contracts on behalf of their firm.
12. COMMUNICATION WITH SBAC EMPLOYEES: Prior to the IFB due date and during evaluation of Bids by SBAC, communication with SBAC employees other than the Purchasing Agent regarding the IFB and the contents therein is prohibited, and shall constitute good cause for disqualifying a Bidder. The Purchasing Department shall issue any material instructions, interpretations, or directions regarding the IFB in writing.
13. CONFLICT OF INTEREST: Contract award is subject to the provisions of 112, F.S. Bidders must disclose with their Bid the name of any officer, director, or agent who is also an employee of SBAC. Further, all Bidders must disclose the name of any Board employee who owns, directly or indirectly, an interest of 5% or more in the Bidder's firm or any of its branches.
14. LOBBYING: BIDDERS ARE HEREBY ADVISED THAT THEY ARE NOT TO LOBBY WITH ANY SBAC PERSONNEL OR BOARD MEMBERS REGARDING THIS BID. ALL ORAL OR WRITTEN INQUIRIES MUST BE DIRECTED TO AND PROCESSED BY THE PURCHASING DEPARTMENT.
- LOBBYING IS DEFINED AS ANY ACTION TAKEN BY OR ON BEHALF OF ANY BIDDER INTENDED TO DIRECTLY OR INDIRECTLY INFLUENCE THE GOVERNMENTAL DECISION OF A BOARD MEMBER OR SBAC PERSONNEL AFTER BID ADVERTISEMENT AND PRIOR TO THE BOARD'S VOTE ON THE AWARD OF THIS CONTRACT.
- ANY BIDDER WHO IS ADVERSELY AFFECTED BY THE RECOMMENDED AWARD MAY FILE A PROTEST WITHIN THE TIME PRESCRIBED IN SECTION 120.57(3), FLORIDA STATUTES.
- VIOLATION OF THIS PARAGRAPH WILL RESULT IN DISQUALIFICATION OF THE BIDDER.
15. COLLUSION: The Bid shall be made without any previous understanding, agreement, or connections with any persons, firms, or corporations making a Bid on the same items and shall be in all respects fair and in good faith without any outside control, collusion, or fraud.
16. INTERPRETATION OF BIDDING DOCUMENTS AND ADDENDA: No interpretation of the meaning of the IFB documents, and no correction of any apparent ambiguity, inconsistency or error therein, will be made to any Bidder orally. To be enforceable, all requests for interpretation, correction, or clarification of the IFB documents shall be made by Bidders no later than 72 hours (weekends, holidays not included) prior to the IFB due date and time. All such requests must be in writing and received by SBAC Purchasing Department no later than 72 hours (weekends, holidays not included) prior to the IFB due date. Following review of such requests by the Purchasing Department, any necessary interpretations and supplemental instructions will be in the form of written Addenda to the IFB documents. Only the interpretation or correction so given by the Purchasing Agent or his authorized designee, in writing, shall be binding and prospective Bidders are advised that no other source is authorized to give information concerning, or to explain or interpret, the IFB documents. Bidders should address any questions regarding this Bid to SBAC Purchasing Department, at A/C 352-955-7582.
- It is the responsibility of the Bidder to frequently check the SBAC Purchasing website at www.sbac.edu/~purchase/bidop.htm to ascertain if any addenda have been posted, to obtain all such addenda, and to return or acknowledge all addenda as required by the IFB documents.
17. LINE ITEM BID CORRECTIONS: The use of correction fluid or erasures to correct line item Bid prices and/or quantities is not acceptable. Corrections must be made by striking through the incorrect information, writing the correct information next to the strikeout, and initially all changes. Correction fluid or erasure corrected Bids will be considered non-responsive for the corrected items only.
18. BIDDER'S ERRORS: Where unit price and total price cannot be reconciled, the quoted unit price shall govern. Where numerical price and written price cannot be reconciled, the written price shall govern.
19. BID WITHDRAWAL, CORRECTION: Prior to the date and time of the public Bid opening specified in the IFB, Bidders may withdraw or correct Bids. No withdrawal or correction will be permitted after the IFB Bid opening date and time.
- A request for Bid withdrawal must be in writing, addressed to SBAC Purchasing Agent, and containing the legally binding signature of the Bidder desiring to withdraw the Bid. A verbal request to withdraw a Bid will not be accepted. A Bid withdrawal request must be received in sufficient time for the Purchasing Department to effect the withdrawal.
- A potential Bidder desiring to correct or amend its Bid must do so by replacing the Bid package currently in the Purchasing Department's possession with a new Bid package, which must meet the requirements of the IFB and be properly sealed and identified in order to be considered for award. An amended or corrected Bid package must be accompanied by a letter requesting that it be substituted for the Bid currently in the possession of the Purchasing Department, must be addressed to SBAC Purchasing Agent, and contain the legally binding signature of the Bidder desiring to correct or amend its Bid. Such a request must be received in sufficient time for the substitution to be made.
20. ONE PRICE ONLY: Bidders shall submit only one price for each product or service listed. If multiple prices are proposed for any single product or service, the Bid will be rejected for that item only.
21. ALTERNATE BID: shall be clearly identified as such on the outside of the Bid package by using the term "ALTERNATE BID" (see page two for additional packaging instructions). If an Alternate Bid is accepted, SBAC will cancel the current procurement and develop a new IFB using as the basis for its specifications the product and/or services contained in the Alternate Bid. Sole source Alternate Bids will typically not be considered by SBAC.
22. BUDGETARY LIMITATIONS: SBAC reserves the right to reject any item or items and/or increase or decrease quantities as required due to budgetary limitations. SBAC also reserves the right to issue Purchase Orders on Bid prices for delivery through the effective date of the Bid.
23. QUANTITY ESTIMATES: Quantities shown are estimated amounts only and are presented to assist Bidders in the development of their Bids. Actual quantities of purchase may be more or less than the amounts shown. Unless specifically addressed and authorized elsewhere in the IFB, minimum cost or quantity order requirements are not allowed. Bids received that have minimum order or cost requirements will be considered non-responsive for the qualified item or lot only, and shall be considered for award for any other items Bid that are responsive in accordance with the requirements of the IFB.
24. SAMPLES: If required, samples submitted by the Bidder, unless elsewhere indicated in this IFB, shall become the property of the SBAC. Samples shall be provided at no cost to the SBAC. Samples must be sealed in a closed envelope, box, or other packaging in such a manner that the sample itself cannot be viewed until the sealed package is opened. The sealed package must be labeled with the IFB number, IFB title, and the IFB opening date and time.
- Unless otherwise specified, all samples must be submitted to the Purchasing Department.

25. **CONDITION OF PRODUCT/SERVICES:** Unless addressed elsewhere in the IFB, all specified products contained in each Bid shall be new, the latest model manufactured, first quality, carry the manufacturer's standard warranty, and meet or exceed the specifications. Used, re-manufactured or reconditioned product, unless specifically authorized elsewhere in the IFB, will not be considered. Any Bidder proposing such items will be deemed non-responsive.
- At any time subsequent to Contract award, SBAC reserves the right to have the product tested for compliance with the specifications by qualified in-house staff or a qualified independent testing laboratory. In the event the product fails the test, the successful Bidder shall replace the defective product(s) at its sole expense, and shall reimburse SBAC for all material and labor costs, if any, associated with installing the non-conforming products.
- In accordance with the IFB, Bidder shall perform all services in a thorough, efficient, and professional manner promptly and with due diligence and care, and in accordance with the best practices of the profession, utilizing qualified and suitable personnel, equipment and materials. If all or any part of the services is found by SBAC to be defective (regardless of whether or not payment for such services has been made by SBAC to Bidder) for reasons attributable to Bidder, Bidder shall refund that portion of compensation made by SBAC for that aspect of the services found to be defective or, at the sole discretion of SBAC, shall reperform the defective services at no cost to SBAC.
26. **FAILURE TO ENFORCE PERFORMANCE:** The waiver by SBAC of any breach or the failure by SBAC to enforce at any time, or for any period of time, any of the terms and conditions of the Contract, shall be limited to the particular instance, shall not operate or be deemed to waive any future breaches of the Contract and shall not be construed to be a waiver of any provision, except for the particular instance.
27. **PURCHASE BY OTHER PUBLIC AGENCIES:** With the consent and agreement of the successful Bidder(s), purchases may be made under this Bid by other governmental agencies within the State of Florida. The same terms and conditions as stated herein shall govern such purchases.
28. **FLORIDA STATE CONTRACTS, "SNAPS" AGREEMENTS, FLORIDA DEPARTEMNT OF EDUCATION CONTRACTS; OTHER CONTRACTS:** if a Bidder currently holds a contract with the State of Florida, Department of Management Services, Division of Purchasing or the Florida Department of Education, to supply the products or services described in this Bid, the Bidder shall quote not more than the prices listed in these approved contracts. Failure to comply with this request may result in disqualification. The purchasing department reserves the right to reject all Bids and purchase from State contracts, SNAPS Agreements or FDOE contracts, if it is in the best interests of SBAC to do so.
- SBAC further reserves the right to utilize any other District contract, any contract awarded by any other city or county governmental agencies, any other school board, any other community college/state university system cooperative bid agreement, or to directly negotiate/purchase per SBAC policy and/or State Board Rule 6A-1.012(6) in lieu of any Bid received as a result of the IFB, if it is in its best interests to do so.
29. **EVALUATION CRITERIA:** In addition to evaluation criteria that may be specified elsewhere in the IFB, unsatisfactory performance by a Bidder on previous Contracts with the SBAC, or with other State or local governments, will be considered during evaluation and may be sufficient cause not to award.
30. **BIDDER REPRESENTATIONS AND QUALIFICATIONS:** Bidder warrants and represents itself to be experienced and an expert in the furnishing of goods and/or services described in the IFB. By submitting a signed Bid, Bidder acknowledges that SBAC is relying on the representations and warranties made by the Bidder.
31. **DISPUTE:** With respect to a protest of the specifications contained in an IFB, the notice of protest shall be filed in writing within seventy-two (72) hours after posting of the IFB on the Purchasing Department's Bid Opportunities web page, and a formal written protest shall be submitted within ten (10) calendar days after the date of filing the notice of protest, for the protest to be considered.
- Bid tabulations with recommendations will be posted on the Purchasing Department's Bid Opportunities web page. Any Bidder who disputes the Contract award recommendation of any Bid shall file a notice of protest in writing within seventy-two (72) hours of the Bid tabulation posting and submit a formal written protest within ten (10) calendar days after the date of filing the notice of protest.
- The formal written protest shall state with particularity the facts and Law upon which the protest is based. Failure to file a protest within the prescribed time, in accordance with 120.57(3), F.S. and in accordance with the procedures set forth in Paragraph 31, shall constitute a waiver of proceedings under Chapter 120, F.S. After the seventy-two (72) hours and ten (10) calendar days have passed without protest, the Board will not consider any protest as being valid. Any notice of protest or formal written protest of the specifications or contract award recommendation shall be filed with the Purchasing Agent.
32. **BID TABULATIONS:** Bid tabulations with recommendations will be posted on the Purchasing Department's Bid Opportunities web page and will also be available for review in the Purchasing Department.
33. **NOTIFICATION OF AWARD:** Unsuccessful Bidders will not receive notification of award. Bid tabulations with recommendations will be posted on the Purchasing Department's Bid Opportunities web page.
34. **DELIVERY:** Unless elsewhere specified, delivery shall be F.O.B. Destination SBAC, with title passing to the School Board of Alachua County upon receipt and acceptance of the goods and/or services.
- Time is of the essence. Delivery and/or service completion dates contained in the IFB, or proposed by the successful Bidder and accepted by SBAC, shall be firm. The Purchasing Department must approve in writing any deviation from the Contracted delivery and/or service completion dates. Failure to complete the Contract within the time agreed upon or cancellation of any item(s) awarded may result in termination of the Contract and debarment of the Bidder from doing business with SBAC.
35. **TAX EXEMPTIONS:** SBAC is exempt from any taxes imposed by the State and/or Federal Government (State Sales Tax Exemption Certificate No. 85-8012621709C-5 and Federal Tax ID #59-60005000). This exemption does not apply to purchase of tangible personal property made by contractors who use the tangible personal property in the performance of contracts for the improvements of SBAC real property as defined in F.S. 192. Tax exemption certificates.
36. **SAFETY STANDARDS:** At a minimum, Bidder warrants that the supplies/services provided to SBAC shall conform in all respects to the standards set forth in the Occupational Safety and Health Act 1970, as amended, and the failure to comply with this condition will be considered a breach of the Contract.
- Bidder will also observe and comply with all safety requirements mandated by Board policy, as well as any specific school and department practices. Failure to comply with these minimum safety requirements will be considered a breach of the Contract. Further, the Bidder may be disbarred from participating in any IFB, Request for Quotation, and other purchases of goods and services made by SBAC for a period of 12 months.
37. **MATERIAL SAFETY DATA SHEETS:** Any items Bid that contain substances found on the current State of Florida Toxic Substances List must include with shipment the appropriate Materials Safety Data Sheets (MSDS), in accordance with F.S. 442.106.

38. **INSPECTIONS:** All goods and/or services are subject to inspection after receipt at destination. Items or services that deviate from the specifications or otherwise fail to conform to the requirements of the IFB will be returned and/or re-performed at the Bidder's risk and expense.
39. **FACILITY INSPECTION:** SBAC reserves the right to inspect or have its representatives inspect the Bidder's facilities, including those of its subcontractors, if any, at any reasonable time.
40. **BIDDER PERSONNEL:** Bidder shall have an adequate number of qualified personnel, who are thoroughly trained and experienced in accordance with industry standards and the requirements of the IFB, to provide the goods and/or services described herein.

Personnel performing services on any SBAC site shall be permanent (full or part-time) employees of the Bidder, unless written permission to use temporary employees is provided by the Purchasing Agent or their designee, who are 18 years or older and who have not been convicted of a felony or first degree misdemeanor. Any Bidder employee involved in any F.S. 435 (Employment Screening) offenses is precluded from working or continuing to work site and shall be replaced. Failure to comply with this requirement may result in Contract termination at the sole discretion of SBAC. Lack of knowledge by Bidder will in no way relieve Bidder from its responsibilities hereunder.

Personnel performing services on any SBAC site shall adhere to SBAC rules and regulations regarding appropriate attire, prohibition of smoking, usage of proper language, prohibition of use and possession of controlled substances and alcoholic beverages, including tobacco and tobacco products, prohibition of the possession of fire arms – either on their person or in their personal or company-owned vehicle, and any other restrictions that may apply.

When accessing any SBAC site, Bidder shall notify department or school personnel and follow customary sign-in procedures. All Bidder personnel shall wear clothing identifying them as an employee of the Bidder (name/logo) and have in their possession at all times a form of picture identification (drivers license, company ID card), which shall be presented immediately upon request of SBAC personnel.

41. **DELIVERY NOTICE:** Unless specified elsewhere, the successful Bidder shall notify SBAC forty-eight (48) hours prior to delivery of product or services provided pursuant to the IFB to ensure availability of receiving personnel. SBAC reserves the right of refusal at delivery location if such prior notice has not been received.
42. **INVOICES:** Unless specified elsewhere, invoices shall be submitted in accordance with one of the following options: Hard copy, in duplicate, to SBAC at Accounts Payable Department, 620 East University Avenue, Gainesville, FL 32601, or via email to accountspayable@gm.sbac.edu. All invoices shall, at a minimum, include the following:
- ✓ IFB #;
 - ✓ Purchase Order #;
 - ✓ Description of goods and/or services, including quantities;
 - ✓ Awarded unit price(s) and extended total(s)

Payment shall be made for goods and/or services provided in accordance with the IFB, completed in full or in substantial quantity, inspected and found to be in compliance with the specifications, and properly invoiced. Payment terms are Net 30 days. The number of days will be computed from the date of the invoice, which shall not be before the day the goods or services are received or provided. Discounts are encouraged and should be included on any invoice when available.

SBAC will not process, and Bidder waives all rights to payment, invoices submitted more than 180 days after the date the goods or services were delivered or performed. Any exception to the 180-day rule must be approved in advance by the Purchasing and Finance Departments.

43. **PUBLIC ENTITY CRIMES AFFIDAVIT:** A person or affiliate who has been placed on the convicted Bidder list following a conviction for a public entity crime may not submit a bid on a contract to provide any goods or services to a public entity, may not submit a bid on a contract with a public entity for the construction or repair of a public building or public work, may not submit bids on leases of real property to a public entity, may not be awarded or perform work as a contractor, supplier, subcontractor, or consultant under a contract with any public entity, and may not transact business with any public entity in excess of the threshold amount provided in Section 287.017, for CATEGORY TWO for a period of 36 months from the date of being placed on the convicted Bidder list.
44. **LICENSING/PERMITS:** Prior to starting work, the successful Bidder shall have obtained any and all licenses and permits required by Federal, State, or Local Governments.
45. **REGULATORY COMPLIANCE:** Bidder shall comply with all applicable federal, state, county, and municipal statutes, regulations, ordinances, and rules pertaining to the furnishing of services and/or goods described in the IFB.
46. **TERMINATION FOR CONVENIENCE:** SBAC shall have the right to terminate any Contract resulting from this solicitation, or any portions thereof, for its convenience upon ten (10) days advance written notice to the Bidder. SBAC shall compensate the Bidder for services satisfactorily rendered through the date of termination. SBAC shall not be obligated hereunder nor likewise liable to pay the Bidder any other costs, losses, damages or expenses arising out of or related to the termination of this contract or any services performed hereunder.
47. **TERMINATION FOR DEFAULT:** SBAC reserves the right to terminate any Contract resulting from this IFB for failure of the Contracted Bidder to adhere to the terms and conditions as specified herein, upon ten (10) days advance written notice to the Bidder. In the event of Contract termination for cause, SBAC may re-procure the supplies and/or services from any other source or sources and the defaulting Bidder shall reimburse SBAC any excess costs incurred thereby.
48. **INDEPENDENT CONTRACTOR:** Bidder(s) shall have the status of an independent contractor. Bidder(s) shall have no right or power to enter into any contract or commitment on SBAC's behalf. Bidder shall be solely responsible for the compensation, benefits, contributions and taxes, if any, of its employees, agents and subcontractors. If SBAC shall be required by law to pay any contribution, tax or penalty because of Bidder's failure to do so, Bidder shall forthwith reimburse SBAC for the entire amount so paid by it.
49. **SUBCONTRACTS:** The Bidder shall not delegate the performance of the services or furnishing of goods in whole or in part, nor retain any contractor to provide any of the services or goods, without first obtaining the written consent of the Purchasing Department.
50. **ASSIGNMENT:** Any Contract between the successful Bidder and SBAC shall not be assigned by the successful Bidder without first obtaining the written consent of the Purchasing Department. Assignment of the Contract or any portion thereof without such written permission shall be grounds for immediate termination.
51. **ANTI-DISCRIMINATION/EQUAL OPPORTUNITY:** Bidder certifies that it is in compliance with the non-discrimination clause contained in Executive Order 11246, as amended by Executive Order 11375, regarding equal employment opportunity for all persons without regard to race, color, religion, sex or national origin.

Further, except as otherwise provided under 41 CFR Part 60, all contracts that meet the definition of “federally assisted construction contract” in 41CFR Part 60-1.3 must include the equal opportunity clause provided under 41 CFR 60-1.4(b), in accordance with Executive Order 11246, “Equal Employment Opportunity” (30 CFR 12319, 12935, 3 CFR Part, 1964-1965 Comp., p.339), as amended by Executive Order 11375, “Amending Executive Order 11246 Relating to Equal Employment Opportunity,” and implementing regulations at 41 CFR part 60, “Office of Federal Contract Compliance Programs, Equal Employment Opportunity, Department of Labor.”

52. **DISCRIMINATION:** An entity or affiliate who has been placed on the State of Florida discriminatory bidder list may not submit a bid on a contract to provide goods or services to a public entity, may not submit a bid on a contract with a public entity for the construction or repair of a public building or public work, may not submit bids on leases of real property to a public entity, may not award or perform work as a contractor, supplier, subcontractor, or consultant under contract with any public entity, and may not transact business with any public entity.

53. **COMMON CARRIER WAIVER:** In the event Bidder and its employee’s will not enter onto SBAC property during the base contract term and any renewal period and if all product or commodity deliveries are made by common carrier, and not by vehicles owned or operated by Bidder, during the base contract term and any renewal period, then Bidder may complete the Common Carrier Insurance form included herein to request an exemption from the IFB’s insurance requirements described the Insurance Certification Form.

54. **INDEMNIFICATION/HOLD HARMLESS AGREEMENT:** Bidder shall, to the fullest extent permitted by law, protect, defend, indemnify and hold harmless SBAC, its elected officials, employees, and agents from and against any and all claims, actions, liabilities, losses (including economic losses), costs, including attorney’s fees, arising out of any actual or alleged: (a) bodily injury, sickness, disease or death, or injury to or destruction of tangible property including the loss of use resulting therefrom, or any other damage or loss arising out of, or claimed to have resulted in whole or in part from any actual or alleged act or omission of the Bidder, subcontractor, anyone directly or indirectly employed by any of them, or anyone for whose acts any of them may be liable in the performance of the work; or (b) violation of law, statute, ordinance, rule, regulation, or infringement of patent rights by Bidder in performance of the work described herein; or (c) liens, claims or actions made by the Bidder or any subcontractor or other party performing the work. The indemnification obligations hereunder shall not be limited to any type of damages, compensation or benefits payable by or for the Bidder or any subcontractor under worker’s compensation acts; disability benefit acts, other employee benefit acts or any statutory bar. Any costs or expenses, including attorney’s fees, incurred by SBAC to enforce this agreement shall be borne by the Bidder.

Notwithstanding the foregoing, the liability herein shall be limited to ten million dollars (\$10,000,000) and the Bidder recognizes that and covenants that is has received consideration for indemnification provided herein.

The Bidder recognizes the broad nature of this indemnification and hold harmless article, and voluntarily makes this covenant and expressly acknowledges the receipt of TEN DOLLARS payable upon receipt of the first invoice and other good and valuable consideration provided by SBAC in support of this indemnification in accordance with the laws of the State of Florida. This article shall survive the termination of this Contract.

55. **DEFAULT:** In addition to other rights and remedies provided herein, in the event the successful Bidder should breach this Contract, SBAC reserves the right to seek all remedies in law and/or in equity. This provision shall survive termination of the Contract, including without limitation termination for convenience

56. **RICHARD B. RUSSELL NATIONAL SCHOOL LUNCH ACT’S BUY AMERICAN PROVISION:** To the maximum extent practicable, the School Board of Alachua County Food Service Department is required to purchase only domestically grown and processed foods, which are defined as commodities or products produced and processed in the United States substantially using agricultural commodities that are produced in the United States. For the purposes of this provision, “substantially” means that over 51% of the final processed product consists of agricultural commodities that were grown domestically. Bidder certifies that each item contained in its Bid complies with Richard B. Russell National School Lunch Act’s Buy American Provision and that at least 51% of the content of each item contained in its Bid consists of agricultural products that were grown domestically. Bidder shall provide documentation verifying domestic origin of products. If a food product(s) does not meet the standards, criteria or intent of the Act, Bidder shall inform SBAC of this fact and SBAC will make the final decision on purchasing the product, in accordance with the best interests of the non-profit child nutrition program.

57. **CONE OF SILENCE:** A Cone of Silence is in effect for this IFB as of the date of its advertisement on the SBAC Purchasing Department Web Page, which is located at www.sbac.edu/~purchase/bidop.htm. The Cone of Silence is designed to protect the integrity of the procurement process by shielding it from undue influences prior to the recommendation of contract award.

The Cone of Silence prohibits any communication regarding this IFB between:

- A. a potential vendor, service provider, Bidder, lobbyist, or consultant and the staff of the Alachua County Public Schools, including school principals; and
- B. a potential vendor, service provider, bidder, lobbyist, or consultant and any one or more of the School Board members or members-elect.

Unless specifically provided otherwise in the IFB, the Cone of Silence does not apply to the following:

- A. Communications between a potential vendor, service provider, Bidder, lobbyist, or consultant and the SBAC’s Purchasing Department;
- B. Communications between a potential vendor, service provider, Bidder, lobbyist, or consultant and the SBAC’s Staff Attorney or School Board Attorney; and
- C. Communications at duly noticed pre-bid meetings and site visits prior to bid opening or post bid-opening meetings and site visits, which are administered by the Purchasing Department prior to issuance of a written recommendation of contract award.

The Cone of Silence terminates at the time the School Board acts on a written recommendation from the Purchasing Department regarding contract award; provided, however, that communications are permitted when the School Board receives public comment at the meeting when the recommendation is presented.

Violation of this article by a potential vendor, service provider, Bidder, lobbyist, or consultant may, in the discretion of SBAC, result in rejection of said Bidder, proposer, respondent and/or representative’s bid, proposal, or offer and may render any contract award to said Bidder, proposer or respondent voidable.

58. **LEASE OR MAINTENANCE AGREEMENT TERMINATION:** Any lease agreement established herein is contingent on annual appropriations by SBAC. SBAC’s fiscal year begins July 1 and ends June 30. SBAC makes appropriations through its budget process that is normally concluded in the month of September. In the event funding of this lease agreement is not approved for any year during its term, SBAC will give notice to successful Bidder no later than September 30, and this lease agreement will terminate thirty (30) calendar days after this notice. At that time, the leased equipment will be returned to successful Bidder and all obligations of the parties to each other shall cease.

Any maintenance agreement established herein is contingent on annual appropriations by SBAC. SBAC's fiscal year begins July 1 and ends June 30. SBAC makes appropriations through its budget process that is normally concluded in the month of September. In the event funding of this maintenance agreement is not approved for any year during its term, SBAC will give notice to successful Bidder no later than September 30, and this maintenance agreement will terminate thirty (30) calendar days after this notice. At that time, all obligations of the parties to each other shall cease.

59. LIFE CYCLE COSTING: If so specified in the IFB, SBAC may elect to evaluate equipment proposed on the basis of total cost of ownership. In using life cycle costing, factors such as the following may be considered: estimated useful life, maintenance costs, cost of supplies, labor intensity, energy usage, environmental impact, and residual value. SBAC reserves the right to use these or other applicable criteria, in its sole opinion, that will most accurately estimate total cost of use and ownership.
60. WARRANTY OF ABILITY TO PERFORM: Bidder warrants that, to the best of its knowledge, there is no pending or threatened action, proceeding, or investigation, or any other legal or financial condition, that would in any way prohibit, restrain, or diminish Bidder's ability to satisfy its Contract obligations. It shall be the responsibility of Bidder to notify SBAC's Purchasing Department if its ability to perform is compromised in any manner during the term of the Contract. In the event Bidder files for bankruptcy, insolvency, or receivership, SBAC may, in its sole discretion, terminate and cancel this Contract, with no penalty whatsoever, in which all rights hereunder shall immediately cease and terminate.
61. RECORDS RETENTION AND ACCESS: Bidder shall retain records associated with the goods and services purchased herein for a period of three years following final payment. Bidder shall, with reasonable notice, provide SBAC access to these records during the above retention period.
62. CONFIDENTIAL INFORMATION: Bidder recognizes and acknowledges that Bidder, its agents, employees, officers, and subcontractors may have access to certain confidential information and processes, including confidential student information, personal health information, financial records, and access to SBAC networks (hereinafter "Confidential Information"). Bidder agrees that neither it nor any agent, employee officer, or subcontractor will at any time, either during or subsequent to the term of the contract resulting from this IFB, disclose to any third party, except where permitted or required by law or where such disclosure is expressly approved by SBAC in writing, any Confidential Information. In addition, following fulfillment of all contractual obligations hereunder, Bidder, its agents, employees, officers, and subcontractors shall either destroy or return to SBAC all Confidential Information. With 72-hours written notification, SBAC reserves the right to determine whether or not Confidential Information has been destroyed and such confirmation may include inspecting the Bidder's facilities and equipment.
63. FLORIDA PREFERENCE: When applicable and pursuant to §287.084 Florida Statutes, award recommendations shall make appropriate adjustments to pricing when considering Bids from Bidders having a principal place of business outside the State of Florida. When applicable, all Bidders must complete and include Bidder's Statement of Principal Place of Business with its Bid. Failure to comply shall render its Bid non-responsive and therefore not subject to contract award.
64. Bidder is required to comply with the Florida Public Records Law, Chapter 119, Florida Statutes, in the performance of Bidders duties under this IFB, and will specifically: a. Keep and maintain public records required by SBAC to perform the service; b. Upon request from SBAC's custodian of public records, provide SBAC with a copy of the requested records or allow the records to be inspected or copied within a reasonable time at a cost that does not exceed the cost provided in the Chapter 119, Florida Statutes or as otherwise provided by law; c. Ensure that public records that are exempt or confidential and exempt from public records disclosure requirements are not disclosed except as authorized by law for the duration of the contract term and following completion of the contract if Bidder does not

transfer the records to SBAC; d. Upon completion of the contact, transfer, at no cost, to SBAC all public records in possession of Bidder or keep and maintain public records required by SBAC to perform the service. If Bidder elects to transfer all public records to SBAC upon completion of the contract, Bidder shall destroy any duplicate public records that are exempt or confidential and exempt from public records disclosure requirements. If Bidder keeps and maintains public records upon completion of the contract, Bidder shall meet all applicable requirements for retaining public records. All records stored electronically must be provided to SBAC, upon request of the SBAC's custodian of public records, in a format that is compatible with the information technology systems of SBAC.

65. NONACADEMIC COMMODITIES AND SERVICES: In accordance with §1010.04 Florida Statutes, SBAC has reviewed the purchasing agreements and state term contracts available under §287.056 Florida Statutes for the nonacademic commodities or contractual services described in this IFB. This review requirement does not apply to commodities or services eligible for reimbursement under the federal government's E-rate program, which is administered by the Universal Service Administrative Company.
- ITEMS 66-74 APPLY ONLY TO WORK FUNDED IN WHOLE OR IN PART BY FEDERAL GRANTS. SBAC WILL INDICATE IN THE "BIDDER ACKNOWLEDGEMENT AND ACCEPTANCE FORM" ABOVE WHICH OF THESE ITEMS APPLY TO THE WORK TO BE PERFORMED BY THE SUCCESSFUL BIDDER(S).
66. COPELAND "ANTI-KICKBACK" ACT: All Bidders and their subcontractors shall comply with the Copeland "Anti-Kickback" Act (40 U.S.C. 3145), as supplemented by Department of Labor regulations (29 CFR Part 3, "Contractors and Subcontractors on Public Building or Public Work Financed in Whole or in Part by Loans or Grants from the United States") on all federally funded contracts exceeding \$2,000. The Act provides that each Bidder is prohibited from inducing, by any means, any person employed in the construction, completion, or repair of public work, to give up any part of the compensation to which he or she is otherwise entitled. SBAC will report all suspected or reported violations to the Federal awarding agency.
 67. DAVIS BACON ACT (as amended (40 U.S.C. 3141-3148)). As required by Federal program legislation, Bidders shall comply with the Davis-Bacon Act (40 U.S.C. 3141-3144, and 3146-3148) as supplemented by Department of Labor regulations (29 CFR Part 5, "Labor Standards Provisions Applicable to Contracts Covering Federally Financed and Assisted Construction") on all federally funded contracts exceeding \$2,000. In accordance with the statute, Bidders must pay wages to laborers and mechanics at a rate not less than the prevailing wages specified in a wage determination made by the Secretary of Labor. In addition, Bidders must pay wages not less than once a week. A copy of the current prevailing wage determination issued by the Department of Labor is included herein. Subsequent wage determinations will be made available to the successful Bidder during the term of the contract as updated by the Department of Labor. Contract award is conditioned upon the acceptance of the wage determination(s) by Bidders. SBAC will report all suspected or reported violations to the Federal awarding agency.
 68. CONTRACT WORK HOURS & SAFETY ACT (34 CFR 80.36(i)(6)): Bidders and their subcontractors shall comply with sections 103 and 107 of the Contract Work Hours and Safety Standards Act (40 U.S.C. 327-330) as supplemented by Department of Labor regulations, 29 CFR, Part 5. This applies to all construction work >\$2,000 and to other work >\$2,500 that involves mechanics and laborers.
 69. CLEAN AIR ACT (42 U.S.C. 7401-7671q.) AND THE FEDERAL WATER POLLUTION CONTROL ACT (33 U.S.C. 1251-1387), AS AMENDED: For Contracts exceeding of \$150,000, Bidder shall comply with all applicable standards, orders or regulations issued pursuant to the Clean Air Act (42 U.S.C. 7401-7671q) and the Federal Water Pollution Control Act as amended (33 U.S.C. 1251-1387). Violations must be reported to the Federal awarding agency and the Regional Office of the Environmental Protection Agency (EPA).

70. BYRD ANTI-LOBBYING AMENDMENT (31 U.S.C. 1352): For Contracts exceeding \$100,000, Bidders shall file the required certification. Each tier certifies to the tier above that it will not and has not used Federal appropriated funds to pay any person or organization for influencing or attempting to influence an officer or employee of any agency, a member of Congress, officer or employee of Congress, or an employee of a member of Congress in connection with obtaining any Federal contract, grant or any other award covered by 31 U.S.C. 1352. Each tier must also disclose any lobbying with non-Federal funds that takes place in connection with obtaining any Federal award. Such disclosures are forwarded from tier to tier up to SBAC.
71. SECTION 6002 OF THE SOLID WASTE DISPOSAL ACT, AS AMENDED BY THE RESOURCE CONSERVATION AND RECOVERY ACT: The requirements of Section 6002 include procuring only items designated in guidelines of the Environmental Protection Agency (EPA) at 40 CFR part 247 that contain the highest percentage of recovered materials practicable, consistent with maintaining a satisfactory level of competition, where the purchase price of the item exceeds \$10,000; procuring solid waste management services in a manner that maximizes energy and resource recovery; and establishing an affirmative procurement program for procurement of recovered materials identified in the EPA guidelines.
72. RIGHTS TO INVENTIONS MADE UNDER A CONTRACT OR AGREEMENT: If the Federal award meets the definition of "funding agreement" under 37 CFR 401.2(a) and the recipient or subrecipient wishes to enter into a contract with a small business firm or nonprofit organization regarding the substitution of parties, assignment or performance of experimental, developmental, or research work under that "funding agreement," the recipient or subrecipient must comply with the requirements of 37 CFR Part 401, "Rights to Inventions Made by Nonprofit Organizations and Small Business Firms Under Government Grants, Contracts and Cooperative Agreements," and any implementing regulations issued by the awarding agency.
73. DRUG-FREE WORKPLACE CERTIFICATION: Tie Bid preference shall be given to businesses with drug-free workplace programs. Whenever two or more Bids, which are equal with respect to price, quality and service, are received by the State or by any political subdivision for the procurement of commodities or contractual services, a Bid received from a business that certifies that it has implemented a drug-free workplace program shall be given preference in the award process. Established procedures for processing tie Bids will be followed if none of the tied vendor(s) have a drug-free workplace program. In order to have a drug-free workplace program, a business shall: a) Publish a statement notifying employees that the unlawful manufacture, distribution, dispensing, possession, or use of a controlled substance is prohibited in the workplace, and specifying the actions that will be taken against employees for violations of such prohibition; b) Inform employees about the dangers of drug abuse in the workplace, the business's policy of maintaining a drug-free workplace, any available drug counseling, rehabilitation and employee assistance programs, and the penalties that may be imposed upon employees for drug abuse violations; c) Give each employee engaged in providing the commodities or contractual services that are under contract a copy of the statement specified in subsection (1); d) In the statement specified in subsection (1), notify the employees that, as a condition of working on the commodities or contractual services that are under contract, the employee will abide by the terms of the statement and will notify the employer of any conviction of, or plea of guilty or nolo contendere to, any violation of Chapter 893 or of any controlled substance law of the United States, or any state, for a violation occurring in the workplace no later than five (5) days after such conviction; e) Impose a sanction on or require the satisfactory participation in a drug abuse assistance or rehabilitation program, if such is available in the employee's community, by any employee who is so convicted; f) Make a good faith effort to continue to maintain a drug-free workplace through implementation of this section.
74. ENERGY POLICY AND CONSERVATION ACT [APPENDIX II TO 2 CRF 200]- Mandatory standards and policies relating to energy efficiency which are contained in the state energy conservation plan issued in compliance with the Energy Policy and Conservation Act (42 U.S.C 6201).
75. PROHIBITION AGAINST CONTRACTING WITH SCRUTINIZED COMPANIES: A Bidder that, at the time of bidding or submitting a Bid for a new contract or renewal of an existing contract, is on the Scrutinized Companies with Activities in Sudan List or the Scrutinized Companies with Activities in the Iran Petroleum Energy Sector List, created pursuant to s. 215.473, is ineligible for, and may not bid on, submit a proposal for, or enter into or renew a contract with an agency or local governmental entity for goods or services of \$1 million or more." Section 215.473 defines a company to include "all wholly owned subsidiaries, majority-owned subsidiaries, parent companies, or affiliates of such entities or business associations, that exists for the purpose of making profit." By submitting a response to this IFB, Bidder certifies that it and those related entities of respondent as defined above by Florida law are not on the Scrutinized Companies with Activities in Sudan List or the Scrutinized Companies with Activities in the Iran Petroleum Energy Sector List, created pursuant to Section 215.473. Any Bidder awarded a contract as a result of this IFB shall be required to recertify at each renewal of the contract that it and its related entities are not on the Scrutinized Companies with Activities in Sudan List or the Scrutinized Companies with Activities in the Iran Petroleum Energy Sector List. SBAC may terminate any contract resulting from this IFB if Bidder or a related entity as defined above is found to have submitted a false certification or been placed on the Scrutinized Companies with Activities in Sudan List or the Scrutinized Companies with Activities in the Iran Petroleum Energy Sector List. Notwithstanding the preceding, SBAC reserves the right and may, in its sole discretion, on a case by case basis, permit a Bidder on such lists to be eligible for, bid on, submit a proposal for, or enter into or renew a contract, should SBAC determine that the conditions set forth in Section 287.135(4) are met.
76. E-VERIFY: (A) Pursuant to Fla. Stat. § 448.095, effective January 1, 2021, Bidder shall use the U.S. Department of Homeland Security's E-Verify system, <https://e-verify.uscis.gov/emp>, to verify the employment eligibility of all employees hired during the term of this Contract; (B) Subcontractors and Consultants: (i) Bidder shall require all subcontractors and consultants performing work under this Contract to use the E-Verify system for any employees they may hire during the term of this Contract, (ii) Subcontractors and Consultants shall provide Bidder with an affidavit stating the subcontractor or consultant does not employ, contract with, or subcontract with an unauthorized alien, as defined by Fla. Stat. § 448.095, (iii) Bidder shall maintain a copy of all affidavits, (iv) Bidder shall, within 24 hours of request by SBAC, provide a copy of affidavit to SBAC; (C) Bidder must provide evidence of compliance with Fla. Stat. § 448.095 by January 1, 2021. Evidence may consist of, but is not limited to, providing notice of Bidder's E-Verify number; (D) Failure to comply with this provision is a material breach of the Contract, and SBAC may choose to terminate the Contract at its sole discretion. Bidder may be liable for all costs associated with SBAC securing the same services, inclusive, but not limited to, higher costs for the same services and rebidding costs (if necessary).
77. PROHIBITION ON CERTAIN TELECOMMUNICATIONS AND VIDEO SURVEILLANCE SERVICES OR EQUIPMENT: (2 CFR §200.216) Pursuant to Public Law 115-232, Section 889, and 2 Code of Federal Regulations (CFR) Part 200, including §200.216 and §200.471, SBAC is prohibited from using federal funds to procure, contract with entities who use, or extend contracts with entities who use certain telecommunications provided by Huawei Technologies Company or ZTE Corporation (or any subsidiary or affiliate of such entities), and video surveillance or telecommunications equipment or services provided by Hytera Communications Corporation, Hangzhou Hikvision Digital Technology Company, or Dahua Technology Company (or any subsidiary or affiliate of such entities). Bidder agrees that it is not providing SBAC with or using telecommunications and video surveillance equipment and services as prohibited by 2 CFR §200.216 and §200.471. By execution of this Agreement, Bidder certifies its compliance with this provision. The Bidder shall pass these requirements down to any of its subcontractors funded under this Agreement. The Bidder shall notify SBAC if the Bidder cannot comply with the prohibition during the performance of this Contract.

78. **DOMESTIC PREFERENCES FOR PROCUREMENTS:** (2 CFR §200.322): As appropriate and to the extent consistent with law, the CONTRACTOR shall, to the greatest extent practicable under a Federal award, provide a preference for the purchase, acquisition, or use of goods, products, or materials produced in the United States (including but not limited to iron, aluminum, steel, cement, and other manufactured products). Consistent with 2 CFR §200.322, the following items shall be defined as: "Produced in the United States" means, for iron and steel products, that all manufacturing processes, from the initial melting stage through the application of coatings, occurred in the United States. "Manufactured products" means items and construction materials composed in whole or in part of non-ferrous metals such as aluminum; plastics and polymer-based products such as polyvinyl chloride pipe; aggregates such as concrete; glass, including optical fiber; and lumber. The requirements of this section must be included in all subawards including all contracts and purchase orders for work or products under this award.

79. **PROHIBITED INFORMATIONAL REQUEST:** The SBAC will not request documentation of, consider, or give a preference based on the vendor's social, political, or ideological interests.

ATTACHMENT B
GENERAL/TECHNICAL SPECIFICATIONS
IFB 24-55
BHS STORMWATER DRAINAGE IMPROVEMENTS

The School Board of Alachua County (“SBAC” or “District”) is seeking prospective Bidders to respond to this Invitation For Bid (hereinafter “IFB”) to provide the specified services in accordance with the following specifications.

1. Scope of Service: The intent of this IFB is to select a service provider (hereinafter “Bidder”), secure firm prices and establish a contract to perform all services required for the stormwater drainage improvements at Buchholz High School per provided construction plan scopes (Appendix A).

Bidder shall be responsible for providing all technical expertise, qualified labor, supervision, customary tools and equipment, specified materials, permitting, safety measures, materials and other services that are necessary for the proper execution and performance of the contract. Bidder shall devote, and cause its personnel to devote, such time, attention, best skill and judgment, knowledge and professional ability as is necessary to perform all services in a manner that is safe, effective, efficient, environmentally acceptable, and compliant with all regulatory requirements.

2. Tentative Schedule:

- April 10, 2024.....Invitation for Bid Issued
- April 17, 2024Mandatory Pre-Bid Site Visit @ BHS (9:30 am)
- April 18, 2024Last Day to Submit Questions
- April 26, 2024Bid Due Date
- May 7, 2024Planned Award Date

3. Pre-Bid Meeting: The District has scheduled MANDATORY pre-bid meeting on Wednesday, April 17, 2024, beginning at 9:30 a.m. at Buchholz High School, 5510 NW 27th Ave, Gainesville, FL 32606. The purpose of meeting is to provide information regarding the project and to give prospective Bidders the opportunity to inspect work site.

4. Award: In order to meet the needs of the District, award shall be made on an all or none basis to the low, responsive and responsible Bidder in the opinion of the School Board. In making recommendation for award, the Purchasing Department shall take into consideration the qualifications of the Bidders, including relevant expertise, experience, and capacity to perform the requirements as specified herein.

5. Contract: Work shall be authorized by issuance of official SBAC Notice to Proceed (NTP). The District anticipates issuing NTP within two (02) business days of Board approval of contract. The IFB document and any issued addendums, successful Bidder’s submitted quotation response, NTP, and purchase order shall constitute the complete agreement between the parties. No other separate document shall be issued.

6. Contract Term: It is the intent of the District that this shall be a one-time purchase. The contract shall commence on the date of the purchase order and shall remain in effect until the work has been satisfactorily completed and accepted by the Facilities Department, and upon completion of the expressed and implied warranty period.

7. Contract Management: All day-to-day operational aspects of contract services shall be scheduled, coordinated, and managed by Jeffrey Klettner, Construction Foreman (hereinafter “District Representative”) under the authority and direction of the SBAC Planning & Construction Department. The service site may also directly communicate service and safety issues to Bidder’s personnel when onsite at facility. All work shall be subject to periodic review to ensure compliance with project specifications, building codes, time schedule, and established quality standards.

8. Bidder Qualifications: SBAC has established minimum Bidder qualifications and, at its sole discretion, may request the apparent low Bidder to provide evidence demonstrating that they have the experience and capacity to comply with the provisions of the pending contract. In order to be considered for award, each prospective Bidder shall meet the following criteria:

- A. Established Business: Bidder shall be an established firm whose sole or primary business includes the provision of services described herein to commercial (business/institutional) accounts. Bidder shall have been continuously engaged in the specified services as the same legal entity within the State of Florida for a minimum of five (05) consecutive years. Demonstration of past successful experience with commercial (business/institutional) accounts, within the State of Florida, similar in scope of this contract shall be required

including extensive project work (> \$100,000). Project experience shall be verifiable. Negative references, in the opinion of SBAC, may be cause for disqualification of Bidder;

- B. Licensures: Bidder shall be licensed to perform all services described herein within the State of Florida, and limits of Alachua County, Florida. Specifically, Bidder either be a Licensed Site Work Contractor and/or a qualified Licensed Landscape company. Bidder shall be licensed and insured to perform all services described herein within the State of Florida, and limits of Alachua County. It shall be the responsibility of Bidder to possess and maintain, for the life of the contract, all other permits, licenses, certificates, and approvals as required by all regulatory agencies having jurisdiction and authority under this contract. Failure to maintain such approvals during term of contract shall be grounds for immediate termination of contract. It shall be the responsibility of Bidder to possess and maintain, for the life of the contract, all other permits, licenses, certificates, and approvals as required by all regulatory agencies having jurisdiction and authority under this contract.
- C. Service: Bidder shall have at time of Bid due date, adequate organization, technical expertise, equipment, facilities, supervisory capability, qualified personnel, and technical tools of the trade to ensure competent, prompt, and efficient service on a District-wide basis in support of this contract.

The failure of Bidder to currently possess all equipment as specified on Form of Proposal may cause disqualification of Bid. SBAC reserves the right to waive this requirement for any specified "secondary" equipment should Bidder have the capability to directly acquire, by rental or other means, and proficiently operate such equipment to the complete satisfaction of District. Specific qualification criteria as appropriate to personnel, service, and equipment is further delineated herein;

- D. Accounting Practices: Bidder shall have the ability to provide accurate, reliable and timely invoices, statements, and other data necessary as required by District.
- E. Financial Capacity: Bidder shall be in sound financial condition and have the financing necessary to adequately maintain the organization, facilities, equipment, and personnel required in the performance of contract.

SBAC reserves the right to inspect and approve the organization, operation, equipment, and facility(s) of apparent low Bidder, and to make sole and final determination as to Bidder's compliance and capability in meeting the requirements of IFB. It shall be the responsibility of Bidder to provide any further evidence and support documentation as deemed appropriate by District within three (03) business days of request. Should SBAC determine, in its opinion, that Bidder does not meet any of the IFB qualification requirements or have the ability or capacity to provide the services as required in this contract, the District may reject the Bid and evaluate next apparent lowest Bidder.

9. Bonding: Letter of Intent from Bidder's surety company stating they will provide payment and performance bonds on behalf of the Bidder for construction services exceeding \$200,000. The Letter of Intent will also state that the Surety Company(s) will provide bonds using AIA Document A312-2010 and that the Surety Company(s) will comply fully with 255.05 F.S. Finally, the Surety Company(s) will provide a copy of its valid certificate of authority issued by the United States Department of the Treasury under 31 U.S.C. ss. 9304-9308.

Bidder will provide complete construction services, as may be required by SBAC, for projects estimated to cost more than \$50,000, but less than \$2,000,000. SBAC shall require successful Offerors to provide payment and performance bonds for projects estimated to cost \$200,000 or more, using AIA Document A312-2010, issued by a surety company acceptable to SBAC. In the absence of any bonding, liquidated damages may apply.

Bond costs will be included in the firm fixed-price pricing submitted by successful Bidder in response to this IFB. The cost of the Bonds shall be borne by the Bidder. The Bonds shall be accompanied by a duly authenticated or certified document, evidencing that the person executing the Bonds on behalf of the Surety had the authority to do so on the date of the Bonds. In the usual case, conferring of that authority has occurred prior to the date of the Bonds, and the document showing the date of appointment and enumeration of the powers of the person executing the Bonds is accompanied by a certification that the appointment and powers have not been revoked and remain in effect. The date of that certification cannot be earlier than the Agreement.

To be acceptable to SBAC as Surety for Performance Bond and Payment Bonds, a Surety company shall comply with the following provisions:

1. The Surety Company is admitted to do business in the State of Florida.
2. The surety company shall have been in business and have a record of successful continuous operations for at least five (5) years.
3. The Surety Company shall have at least the following minimum ratings:

Contract Amount		Rating*	(Best's Financial Rating)*
0	to 100,000	A-	Class VII
100,000	to 500,000	A	Class VIII
500,000	to 750,000	A	Class IX
750,000	to 1,000,000	A	Class X
1,000,000	to 1,500,000	A	Class XI
1,500,000	or more	A	Class XII

*A.M. Best's Policyholder's Rating of "A" (which signifies A=Excellent, based upon good underwriting, economic management, adequate reserves for undisclosed liabilities, net resources for unusual stock and sound investment).

4. The surety company shall not expose itself to any loss on any one risk in the amount exceeding 10% of its surplus to policy holders, except in instances where:
 - (a) Any risk or portion of any risk which shall have been reinsured in which case, these minimum requirements contained herein also apply to the reinsuring carrier. Such excess of ten percent (10%) assumed by the Insurance Commissioner to do such business in this state shall be deducted from the exposed loss on any risk in determining the limitation of risk prescribed in this section.
 - (b) In the case of a surety insurance company, there shall be deducted, in addition to the deduction for reinsurance, the amount assumed by any co-surety. The value of any security deposited, pledged or held subject to the consent of the surety and for the protection of the surety.

10. Omissions from the Specifications: Reference Attachment A, “7. Silence of the Specifications”: In addition...The apparent silence of this specification on any details, or omissions from them of a detailed description, concerning any point, shall be regarded as meaning that only the best commercial trade practices are to prevail and that all specified services are performed in an efficient and timely manner in compliance with District and industry standards, and all regulatory requirements. All interpretations of this contract shall be made upon the basis of this statement.

11. Subcontractors: Reference Attachment A, “49. Subcontracts”: In addition...Bidder shall not subcontract any portion of the contract services as described herein. All services shall be performed by Bidder’s employees under its direct supervision.

Should it be necessary to subcontract any specialized services that are not customarily provided by site work or landscape contractors in the service trade, it shall be the responsibility of Bidder to identify sub-tier contractor on their bid response and receive written approval from District Representative prior to commencement of services. The District reserves the right to reject to reject said sub-tier contractor based on not meeting qualification criteria, or who has preciously failed in the performance of similar contract, or who is not in the position, in District’s opinion, to perform the specified services in a satisfactory manner.

Bidder shall be held directly responsible and liable for the actions of all sub-tier contractors and the actions of sub-tier contractors’ employees. The sub-tier contractor shall be equally responsible for meeting all specified requirements of this contract including maintaining all insurance as required herein. All subcontracted services that have been approved by District shall be billed by Bidder at net cost. Bidder may charge an additional amount, as cover for overhead and profit, not to exceed fifteen percent (15%) of sub-tier contractors billable total. The invoice shall clearly show description of services, cost, and percent mark-up cost. A copy of sub-tier contractor’s invoice shall be submitted with Bidder’s invoice. Payment for sub-tier contractors’ services shall be made directly to Bidder.

12. Regulatory Compliance: Reference Attachment A, “45. Regulatory Compliance”: In addition...Bidder shall comply with all current laws, rules, codes, ordinances, and licensing requirements that are applicable to the conduct of its business including those of Federal, State, and local agencies having jurisdiction and authority. By way of example, this shall include the: State Requirements for Educational Facilities (SFEF); Florida Administrative Code (FAC);

American with Disabilities Act (ADA); Florida Building Code (FBC); OSHA Safety Standards; and, Environmental Protection Agency (EPA). It is understood that should any provisions of applicable Federal, State or local laws, ordinances and regulations be in conflict with the conditions of this contract, the laws, ordinances and regulations shall be the governing factor for performance of this contract. In addition, should there be a conflict between applicable regulations, the most stringent shall apply. Failure of Bidder to comply with any regulatory agency having jurisdiction and authority over the services described herein shall be grounds for contract termination.

13. Personnel: Reference Attachment A, “40. Bidder Personnel”: In addition...Bidder shall employ and have available an adequate number of trained, qualified, and physically able personnel capable of performing the scope of work as specified herein. The District recognizes the consequences of having substandard work performed and considers the expertise, experience and training of personnel a critical element of this contract. It is therefore the intent of the District to establish personnel qualifications herein that would ensure that work is performed safely, correctly, and efficiently, in conformance to District and industry standards, and any and all regulatory requirements. All assigned personnel have the physical ability to bend, stoop, twist and stand for extended periods of time under varied and sometime extreme climatic conditions.

The following minimum qualifications shall apply to any and all labor provided under the pending contract and shall be considered in the development of bid.

13.1 Project Manager: Bidder shall designate one (01) Project Manager who shall be responsible for providing consultations, conducting periodic quality control inspections, and providing general direction to work crew including site safety briefings. Project Manager shall have extensive knowledge and experience in all facets of stormwater drainage improvement services.

Each assigned Project Manager shall meet the following minimum requirements:

- Five (05) years continuous and extensive field experience working in the service trade of which a minimum of two (02) years shall be in a leadership capacity;
- Considerable knowledge of trade standards;
- Ability to provide technical assistance;
- Considerable knowledge of applicable rules, regulations, and codes governing work, including OSHA safety standards;
- Ability to implement and monitor established safety policies, procedures and regulations;
- Ability to resolve project quality, scheduling and progress problems;
- Ability to generate work proposal estimates based on personnel and equipment requirements.

The cost of Project Manager’s services shall be an element of the Bidder’s overhead burden in the proposed bid price.

14. Onsite Supervision: It shall be required that Bidder employ and provide continuous onsite supervision, of sufficient quality necessary for the effective and efficient management of each project. Bidder shall assign one (01) Project Manager at project worksite who shall perform in a supervisory capacity.

Project Manager shall have demonstrated supervisory skills including having the ability to plan, organize, direct and prioritize the work of Bidder’s personnel, and shall be knowledgeable of supervisory practices, procedures, inspection techniques, codes, ordinances and regulations, and record-keeping and reporting duties. It is understood that Project Manager shall be present at worksite at all times, and shall have the authority to act in the behalf of Bidder in carrying out any instructions relative to work as communicated by District Representative.

The responsibilities of Project Manager shall typically include, but not be limited to:

- Planning and laying out work and work sequences;
- Determining equipment and material requirements;
- Directing all personnel work activities at worksite;
- Providing technical assistance;
- Intervening without delay should corrective action be necessary;
- Reviewing and resolving project quality, scheduling and progress problems.
- Evaluating the progress of work for completeness, accuracy and conformance with work proposal;

- Implementing and monitoring established safety policies, procedures and regulations;
- Determining when project is ready for final inspection.

The cost of onsite supervision shall be an element of Bidder's overhead burden in the proposed hourly labor rates.

15. Certification: By submission of Bid, Bidder certifies that all personnel to be assigned duties in the performance of contract currently meet all qualification criteria as specified, and have been properly screened and hired in accordance with all applicable Federal, State and local laws, ordinances and regulations. Bidder shall be required at any time during term of contract to provide evidence of qualifications of any personnel assigned duties. The assignment of any personnel not meeting minimum qualifications shall be grounds for contract termination.

16. Personnel Conduct: Reference Attachment A, "40. Bidder Personnel": In addition... Bidder's personnel while on location at any District site are expected to maintain a high standard of civility, deportment, appearance, and act in a professional manner at all times. Personnel shall not at any time fraternize with students, teachers, or other District staff not directly involved with the contract services. When in contact with school personnel, Bidder's personnel shall be courteous, helpful, and reflect appropriate courtesies and forms of address.

Specifically, all personnel shall adhere to the following rules and regulations while onsite at any facility:

- Smoking, vaping, and use of any tobacco products is prohibited;
- No personnel shall be allowed in any area other than the area of work responsibility or authorized break or office area without previous knowledge of Project Manager;
- No personnel shall use District telephones (except for an emergency). Any telephone charges incurred by Bidder's personnel and verified by the District shall be billed to Bidder;
- No personnel shall be accompanied or visited by acquaintances, family members or any other non-employee of Bidder.

Violation of this provision may result in removal of the individual(s) involved from the District site. Bidder may furthermore be prohibited from employing the individual(s) in any future work with the SBAC performed under this contract.

17. General Service Guidelines:

a. **General Supervision:** Bidder shall be responsible for all methods, techniques, sequences and procedures and for coordinating all portions of the work under this contract. It shall be the sole responsibility of Bidder to ensure that services are being accomplished correctly and safely in conformance to specifications and all regulatory codes, and that progress is being made sufficient to meet each project's schedule. Bidder shall work jointly and cooperatively with District Representative to resolve any performance issues and scheduling problems.

Bidder's establishment of quality control standards and a system for inspecting and correcting work deficiencies is critical to the success of contract. The failure of the District to immediately reject any unsatisfactory work or to notify Bidder of such deficiencies shall not relieve the Bidder of any responsibilities specified herein. The cost of general supervision shall be an element of the Bidder's overhead burden in the hourly labor/service rates bid.

b. **Bidder's Representative:** Bidder shall provide, on Form of Proposal, the name, telephone and/or cell-phone number of the designated Account Representative to contact regarding service scheduling and other service related issues. Account Representative shall be knowledgeable and familiar with contract and shall be the liaison between the Bidder and the District on all matters pertaining thereof. Designated Account Representative shall respond to all non-emergency calls from the District requesting assistance within twenty-four (24) hours of initial contact.

c. **Communications:** Bidder shall maintain a toll-free telephone and facsimile terminal by which the District may directly and immediately communicate project requirements and other messages during normal business hours (Monday – Friday) from 7:00 a.m. to 3:30 p.m. Email may also be an acceptable form of communication.

d. **Site Access:** It shall be the responsibility of Bidder to coordinate site access directly with the District Representative or with the appropriate authority at each District site. Upon arrival at worksite, personnel shall comply with customary check-in procedures and all security standards. Personnel shall only access designated work areas; all other areas shall be off limits. All personnel shall possess and display the SBAC issued photo ID card which shall be presented immediately upon request by District personnel. While on site, Bidder shall perform

all services with a minimum amount of disruption to the normal operations of the District site. For the safety of staff and students, Bidder is cautioned to avoid performing services during periods of peak student activity.

- e. **Uniforms and Protective Clothing:** It shall be required that Bidder's personnel wear distinctive uniform clothing identifying them as Bidder's employees while on District property. Bidder shall provide all personal protective items required to safely perform work. All such items shall be in conformance with OSHA requirements and any other regulatory agency having jurisdiction and authority.
- f. **Site Examination:** Prior to performance of work, Bidder shall visit worksite, become familiar with the conditions under which the work is to be performed, and correlate personal observations with the job requirements as communicated by the District Representative. Bidder shall inform District Representative of any concerns or issues regarding project work at time of site examination.
- g. **Progress Inspection:** The District reserves the right at any time to conduct periodic inspections of work. Bidder shall comply with all work progress notification requirements as directed by District Representative. The failure of District to perform progress inspections and immediately reject any unsatisfactory work shall not relieve Bidder of any responsibilities specified herein.
- h. **Change Orders:** The District Representative, without invalidating the purchase order, may order changes in the work, within the general scope of this contract, consisting of additions, deletions, or other revisions, with the work proposal "firm fixed-price" being adjusted accordingly. Bidder in not authorized to proceed with work without a written change order approved by District Representative.
- i. **Correction of Work:** Bidder shall promptly correct all work rejected by District Representative as faulty, defective, or failing to conform to contract or Work Proposal, whether observed before or after substantial completion of the work, and whether or not completed. Deficiencies noted shall be documented and remedy effected within five (05) business days of notification, unless additional time is required and granted by the District Representative. It is understood that any follow up or call back work, to correct recent previous work, shall not be charged to SBAC if the work is the result of Bidder's negligence.
- j. **Final Acceptance of Work:** Upon completion of work, Bidder shall contact District Representative and make request for final inspection. District Representative shall inspect work within a reasonable time and notify Bidder of any deficiencies. Bidder shall correct all noted deficiencies within the time specified herein. Should Bidder fail to correct deficiencies in an acceptable and timely manner, the District may, after written notice of default, accomplish the work in an expeditious manner, and charge Bidder the cost of work.
- k. **Safety Measures:** Reference Attachment A, "36. Safety Standards": In addition... Bidder shall take all necessary steps to protect the students, faculty, and general public from injury in the course of the work. Bidder shall specifically warn its employees of the potential hazards of working in the proximity of students and of the necessity for them to exercise extreme caution. Bidder shall be responsible for the discovery, determination, and correction of any unsafe conditions arising in connection with the performance of work. While onsite, Bidder shall not obstruct any passageways or other means of egress and shall not leave the worksite without first securing the work area and eliminating any hazardous condition resulting from its activities. If necessary, Bidder shall place suitable barricades and/or post hazard signs in and around worksite. Bidder shall comply with all applicable Federal, State, and local safety rules and regulations including that of the Occupational Safety and Health Act (OSHA).
- l. **Additional Safety Standards:** Bidder shall observe and comply with all safety standards as contained in the "School Board of Alachua County Safety Guide". Bidder shall be held responsible for the safety of its employees and any unsafe acts or conditions that may cause injury or damage to any persons or property within and around the worksite.
- m. **Asbestos:** Should any Bidder's personnel encounter materials that they suspect are embedded with asbestos, they should: (1) Stop all work at site and not disturb the area of suspicion; (2) Call the District Representative and advise of discovery; and, (3) Leave worksite until further notice subject to analysis of materials.
- n. **Protection:** Bidder shall take all necessary, ordinary and extraordinary precautions to ensure that District property is protected from Bidder's activities. Bidder shall be responsible for the protection of all District facilities and other improvements (i.e., vegetation, pavements, etc.) against operations that may be hazardous and/or damaging to said property. It shall be the responsibility of Bidder to notify District Representative of any unavoidable

damage to District property that may occur prior to commencement of work. Such notification may relieve Bidder of all or part of responsibility for unavoidable damage or loss of property.

- o. **Utilities:** Bidder shall be cognizant of, and operate with due care in the vicinity of all existing surface and underground utilities. All underground utilities shall be located and appropriately marked prior to commencement of any projects requiring excavation in compliance with Chapter 556, Underground Facility Damage Prevention and Safety Act, F.S. It shall be the responsibility of Bidder to contact Sunshine State One Call of Florida and request a locate ticket for each project as required (www.callsunshine.com, 811, or (800) 432-4770). The cost of coordinating all activities relating to this requirement shall be an element of the Bidder's overhead burden in the established hourly labor/service rates.
- p. **Property Damage:** Bidder shall be liable for all damages to District and private property occasioned in any way by its actions or neglect or that of his agents or employees. All such damage or loss of property incurred as the result of Bidder operations, whether through negligence or the lack of proper care, storage, or handling, shall be the responsibility of Bidder to immediately restore or replace at own expense. Should any public or private property be damaged or destroyed, the Bidder at its expense, shall repair or make restoration as is practical and acceptable to the District and owners of destroyed or damaged property, within five (05) business days of discovery unless a time extension is otherwise approved by the District.

In the event Bidder fails to repair damages within specified time, the District may arrange for repairs from other source and appropriately charge Bidder repair cost.

- q. **Cleaning-up/Debris Disposal:** Bidder shall be responsible for scheduling periodic removal and proper disposal of all debris as a result of operations. The worksite shall be left in a safe and orderly fashion at the end of each workday. Accumulated debris shall not be allowed to create a safety hazard to student, staff, and general public. Debris shall not be burned, buried, left for a collector, or placed in a District solid waste dumpster at worksite. All disposal of debris shall be performed in a legal manner in accordance with existing State, County and City regulations. The District shall reimburse Bidder, upon submittal of paid receipt, for any waste disposal fees paid in association with such activities at a legal sanctioned private or municipal landfill. The District shall provide construction roll-off dumpsters for any work involving extensive demolition services. Any request for roll-off dumpsters shall be subject to the approval of District Representative. At completion of work, Bidder shall remove all work materials, tools, equipment, and surplus materials and shall leave worksite in ready to use condition.
- r. **Hazardous Material Storage/Disposal:** All questions regarding the storage and disposal of hazardous waste materials shall be directed to the District Representative. Unused paint and chemicals shall not be disposed of in District facility refuse containers.
- s. **Salvage:** All salvage materials, including that of questionable value, removed during any work performance under this contract shall remain the property of District. Bidder may be required to dispose of unwanted salvage materials or transport materials to a District site upon request of District Representative.
- t. **Invoices:** Reference Attachment A, "42. Invoices". In addition... Bidder shall have the capability to provide accurate, reliable and timely invoices, statements, and credits. At a minimum, invoices shall contain sufficient information, as required by the District, to accurately determine the extent of services provided and accuracy of billing. Invoices shall contain, at minimum, the following information: invoice number; invoice date, bid number; purchase order number; description of services; awarded pricing.

Bidder shall ensure that all invoices reflect correct Bid pricing and are submitted in entirety within ten (10) business days of completion of project. For large project work over an extended time period, the District Representative may authorize progress payments be made to Bidder. Invoices shall be **emailed** to the address appearing on the face of the Purchase Order. It shall be the responsibility of Bidder to identify to District Representative any charges that are unsettled at the time of submission of invoice and before closing of the project

- u. **Invoice Verification/Correction:** It shall be the responsibility of District Representative or other designated personnel to verify and approve all invoices and notify Bidder should any billing errors be discovered. Bidder shall promptly resolve any and all billing discrepancies.
- v. **Final Payment:** It is agreed and understood that the issuance of final payment by the District shall constitute the closing of the project and the acceptance of final payment by Bidder shall constitute a waiver of all further claims relating to project. The making of final payment shall not constitute a waiver of any claims by the District and

shall not relieve Bidder of the responsibility for negligence, faulty materials, or workmanship to the extent within the period provided by law and by the warranties provided herein. SBAC reserves the right to partially pay (short pay) invoices should reasonable justification be presented by District Representative that all project work has not been satisfactorily completed.

18. Equipment: Bidder shall maintain and have readily available all equipment, service vehicles, hand/power tools, and accessories of trade customarily used in the service trade, and as necessary to adequately and efficiently perform its contractual duties.

Any dispute concerning the interpretation of customary equipment shall be resolved by the Purchasing Department in consultation with the Facilities Department. The cost of customary equipment, tools, and accessories as required, shall be an element of Bidder's overhead burden. Unless as otherwise permitted herein, SBAC shall not be charged for any auxiliary equipment (i.e., service trucks, etc.) utilized in the maintenance or support of specified equipment. Furthermore, the District shall not be charged for equipment down time lost due to equipment failure, or for routine maintenance or cleaning.

It is understood that having the necessary and operable equipment is critical to the performance of the contract. Failure of Bidder to commence or complete the project as a result of not having necessary equipment at any time during term of contract shall be grounds for contract termination.

19. Price: Bid single all-inclusive price per lot to be charged SBAC for any or all lots as listed on Attachment C, Form of Proposal. Pricing bid shall be inclusive of all aspects of services required including: supervision; labor; technical expertise; service vehicles; customary equipment, tools, and trade accessories; transportation; travel time; insurance; profit; and, any other direct and indirect cost associated with the execution and administration of the contract. No additional costs, expenses or surcharges (i.e., mileage, fuel, travel time, Visa™ purchasing card processing fee, etc.) shall be applicable to this contract unless specifically permitted herein.

20. Allowances: Allowances for work described in this Section shall be used for additions and/or deletions to the Contract. The price of this work shall include all labor and materials, delivery to site, handling at site, protection from elements, and Bidder's and subcontractor's overhead and profit. Allowance shall be \$10,000, to be used at SBAC's discretion for unforeseen conditions.

21. Liquidated Damages: In the event of delay in project completion, the Bidder shall pay liquidated damages to the District in the amount of \$250 per day. Delays caused by Force Majeure events or by actions of District shall not constitute a delay resulting in the payment of liquidated damages.

22. Bid Tabulation/Evaluation: The award total shall be made by lot to the low, responsive, and responsible Bidder meeting Bid terms, conditions and specifications.

23. Warranty: Reference Attachment A, "25. Condition of Product/Services": In addition... All services provided by Bidder in the performance of this contract shall adhere to the customary, reasonable, and prudent standards of care as established within the industry, and quality of services shall meet or exceed that provided to other commercial customers. Specifically, Bidder shall warrant that all workmanship conforms to project specifications and be of the highest quality, free from faults and defects for a minimum period of twelve (12) months. Payments in full or otherwise shall not constitute a waiver of this guarantee. It is agreed and understood that all services shall be performed to the complete satisfaction of SBAC. Should any services be required to be re-performed, such services shall be completed within five (05) business days of notification at no additional expense to the District. In the event Bidder fails to correct defects within specified time, the District reserves the right to have the work remedied from other service provider. In such case, Bidder shall be fully liable for all costs and expenses reasonably incurred by the District.

24. Service Complaints: All performance related service complaints shall be reported by District Representative to Account Representative or other appropriate designated Bidder's representative. It shall be the responsibility of Bidder to promptly resolve reported complaints pursuant to the applicable terms of this Agreement. Consistent delays or unresponsiveness in addressing and resolving documented deficiencies in the performance of any part of this contract shall be recorded and considered in contract renewal evaluation as well as being a basis for contract termination.

25. Habitual Violator: Reference Attachment A, "47. Termination for Default": In addition... Should the District determine that the number of complaints at any project or cumulatively within the District be excessive, the Purchasing

Department shall schedule a meeting with Bidder to discuss the specific issues. Within five (05) business days of meeting, Bidder shall provide the Purchasing Department a follow-up letter outlining the corrective action(s) to be taken and time sequence by which resolution of issues can be expected. All aspects of proposed plan for corrective action shall be subject to approval of the Purchasing Department.

In the event that documented complaints have not been adequately resolved to the satisfaction of the District or Bidder's record of performance continues to show, in the opinion of the District, that Bidder is frequently, regularly or repetitively defaulting in the execution of any services required in this Agreement, and regardless of whether Bidder has remedied any individual complaint, Bidder shall be deemed a "habitual violator". In such case, Bidder shall forfeit the right to any further notice or grace period to correct, and all of said complaints shall be considered cumulative and collectively and shall constitute a condition of incurable default; thereby being grounds for immediate termination of this Agreement within time as specified.

SCOPE OF WORK AND TECHNICAL SPECIFICATIONS

FOR ADDITIONAL SPECIFICATIONS AND REQUIREMENTS PLEASE REVIEW APPENDIX A- CONSTRUCTION PLANS FOR BUCHHOLZ HIGH SCHOOL BATTING CAGE DRAINAGE IMPROVEMENTS

GENERAL NOTES

1. The topographic and existing information shown hereon were taken from a topographic survey prepared by CHW, and dated July 8, 2022, and revised on January 2, 2024.
2. The location of all existing utilities shown on the plans has been determined from the best information available. The engineer assumes no responsibility for accuracy. It shall be the Contractor's responsibility to notify the various utilities and to make necessary arrangements for any relocation of these utilities with the owner of the utility. The Contractor shall exercise caution when crossing any underground utility, whether shown on the plans or located by the utility company. The respective utility companies shall relocate all utilities that interfere with the proposed construction. The Contractor shall cooperate with the utility companies during the relocation operations. Any delay or inconvenience caused to the Contractor by the various utilities shall be incidental to the contract and no extra compensation will be allowed.
3. The Contractor shall exercise extreme caution in areas of buried utilities and shall provide at least 48 hours' notice to the appropriate utility companies in order to allow marking of the locations of existing underground facilities in advance of construction by calling the Florida Sunshine State One-Call Center, Inc. at 1-800-432-4770 or 811. It is the Contractor's responsibility to notify "Sunshine" 48 hours prior to any clearing of construction to identify all utility locations. No construction activity may occur until the utilities have been properly marked.
4. The Contractor shall field verify the horizontal location and vertical location of all existing utilities within the limits of the project envelope shown prior to commencing work. The Contractor shall call all utility companies to have the locations of all utilities field marked prior to commencement of construction. Any discrepancies shall be brought to the attention of the engineer prior to continuing construction.
5. The Contractor is responsible for repairing any damage to existing facilities, above or below ground that may occur as a result of the work performed by the Contractor.
6. All private and public property affected by this work shall be restored to a condition equal to or better than existing conditions before commencing construction work, unless specifically exempted by the plans. Additional costs are incidental to other construction and no extra compensation will be allowed.
7. All work performed shall comply with the regulations and ordinances of the various governmental agencies having jurisdiction over the work including landscaping.
8. It is the Contractor's responsibility to become familiar with the permit and inspection requirements of the various governmental agencies. The Contractor shall obtain all necessary permits prior to construction and schedule inspections according to agency and/or municipality instructions.
9. It shall be the sole responsibility of the Contractor to comply with and enforce all applicable safety regulations.
10. The Contractor shall be responsible for protecting excavations against collapse and shall provide bracing, sheeting or shoring as necessary. Trenches shall be kept dry while pipes are being placed. Dewatering shall be used as required, and permitted through local government agencies and water management district per current regulations at the sole cost of the Contractor.
11. Contractor to review geotechnical report and borings prior to bidding the project and follow outlined construction techniques.
12. The Contractor is responsible for coordinating applicable testing with the services of an approved testing laboratory and/or soils engineer, applicable regulatory agencies, and as may be found in the engineering construction drawings or specifications. Contractor to verify all testing with the owner prior to commencing construction. Upon completion of the work, the testing laboratory and/or soils engineer must submit to the owner's Engineer certifications stating that all requirements have been met.

13. Install silt fence prior to site demolition or new site construction. Install silt fence per Florida Stormwater Erosion and Sedimentation Control Inspector's Manual or provide toe-in. The Contractor shall maintain the silt fence in working order throughout the construction phase. The project silt fence shall be inspected daily and any corrective measures shall be completed within 24 hours.
14. All tree barricades and silt fencing shall be installed and inspected by Alachua County School Board Representative prior to commencement of any demolition or construction activities.
15. The Contractor is to prepare the site prior to beginning actual construction in accordance with geotechnical report.
16. All deleterious material (i.e. muck, peat, buried debris) is to be excavated in accordance with these plans or as directed by the District's Engineer or Soil Testing Company. Deleterious material is to be stockpiled and removed from the site. Excavated areas are to be backfilled with approved materials and compacted as shown on these areas.
17. Contractor shall clear and grub only those portions of the site necessary for construction. Disturbed areas shall be sodded, seeded, mulched or planted with other approved landscape material, as directed by these plans, immediately following construction per local inspector.
18. Work being performed under this contract shall interface smoothly with other work being performed on the site by other contractors and/or utility companies. It will be necessary for the Contractor to coordinate and schedule their activities, where necessary, with other contractors and utility companies.
19. All pavement dimensions shown are to edge of pavement unless otherwise noted.
20. The governing standards and specifications, unless stated otherwise, shall be per Florida Department of Transportation Standard Plans (FY 2023-24 Road Construction), and Standard Specifications for Road and Bridge Construction dated January 2018, as amended by contract documents. All materials and methods shall meet FDOT specifications and shall be produced or obtained from an FDOT approved source.
21. All new traffic control devices (signs and pavement markings) shall conform to the Manual on Uniform Traffic Control Devices (MUTCD) and FDOT standards.
22. All striping within the FDOT right of way shall be placed first as temporary striping followed by application of thermoplastic striping 30 days later.
23. Contractor is responsible for maintaining proper benchmarks on-site. Existing benchmarks scheduled for removal shall be relocated at Contractor's expense and re-established by a licensed surveyor.
24. All handicap ramps shall comply with the Florida Accessibility Code and Americans with Disabilities Act.
25. A pre-construction conference shall be required. The Contractor, engineer of record, and the owner shall meet with the Alachua County School Board representative prior to initiation of site construction.
26. Any change order requests, site revisions, and pay requests must be submitted to and approved by the engineer of record.
27. Contractor is responsible for all dewatering as needed throughout all construction activities covered by these plans. Dewatering shall be done in accordance with FDOT standard specifications, 2018 Edition, Section 120.
28. The Contractor is responsible for the performance and cost of all clearing and grubbing and all work of removal, disposal, and repair or replacement of existing improvements where shown in the plans, or ordered by the engineer to be removed, or where required because of the construction operations, in order to construct the proposed improvements (this includes but is not limited to proposed piping, structures, utilities, paving, curbing, etc.).
29. An as-built survey may be required by regulatory agencies. Contractor to coordinate with project owner for completion of as-built surveys prior to project/permit close-out.

DEMOLITION GENERAL NOTES

1. The Contractor shall be responsible to dispose of all demolition materials in a safe and lawful manner. The Contractor shall salvage to the District any item as determined by District. Once demolished, material shall be disposed of properly and immediately.
2. Remove all improvements defined on the demolition plan. Salvage items to District as defined by the District's representative and construction document specifications.
3. Existing pavement and sidewalk edges that border new construction or demolition are to be saw-cut to provide a smooth transition.
4. All existing trees are to remain unless otherwise noted.

5. Roots larger than 1 inch in diameter on trees to be preserved that are encountered during construction must be cut cleanly and covered over with soil by the end of the working day.
6. All asphalt and limerock will be completely removed from areas that will be landscaped. In particular, areas where asphalt will be removed must have the top hard surface, limerock, and compacted soil removed. Replacement soil shall be clean deep fill of PH5.5-6.5. The depth of uncompacted soil prior to planting must be at least 3 feet to accommodate future tree root growth. No limerock, large stones, or other construction debris can remain in areas to be landscaped.

PAVING, GRADING AND DRAINAGE GENERAL NOTES

1. The Contractor is responsible for erosion/sedimentation control practices during construction to minimize on-site erosion/sedimentation and to protect against damage to off site property. The following practices shall be employed:

A. Erosion and sedimentation control shall be the responsibility of the Contractor. Areas of off-site discharge during construction shall be protected with a sediment barrier per Florida Stormwater Erosion and Sedimentation Control Inspector's Manual to prevent off-site discharge of sediments. A silt barrier shall specifically be required, constructed, and maintained as indicated on Appendix A. Temporary seed and mulch should be used to control on-site erosion when it is not practical to establish permanent vegetation. Sod shall be placed as early as possible on slopes steeper than 5ft. horizontal to 1ft. vertical. Sod shall be pinned as required. All erosion and sedimentation control measures shall be maintained in working order throughout the construction phase. The Contractor shall inspect and repair as necessary the erosion/sedimentation protection at the end of each working day.

B. NOTE: Erosion/sedimentation control shall be placed prior to site excavation and shall remain in place until site vegetation and landscaping is complete.

C. All inlet structures and pipe shall be protected from siltation by constructing inlet protection as defined by these plans or in the FDOT standards. If siltation occurs, the Contractor is responsible to remove siltation as part of the base contract at no additional cost to the owner.

D. Excavated stormwater facilities shall be constructed as part of the initial construction. The facilities shall be rough graded to the design elevations. After the contributing drainage area is stabilized. The facilities bottom shall be over-excavated by six inches, scarified, backfilled with archer fill (having no more than 5% passing No. 200 sieve), and graded to final design grades. Excess and unsuitable soils shall be removed from the basin (removed all accumulated silts, clays, organic, and debris). Finally, scarify and rake bottom and vegetate.

E. Permanent vegetative stabilization shall be applied on fine graded sites as soon as practical. Temporary seeding should be employed to prevent exposure of barren soils until permanent vegetation can be applied.

F. All slopes 1:3 or steeper require lapped or pegged sod.

G. Erosion, sediment and turbidity control are the responsibility of the Contractor. These delineated measures are the minimum required, with additional controls to be utilized as needed, dependent upon actual site conditions and construction operation.

H. All synthetic bales, silt fence, and other erosion control measures shall be removed at the completion of the project.

2. The Contractor shall maintain in their possession a copy of the Water Management District Construction Permit. Contractor shall be responsible for adherence to all conditions contained in the permit.

3. Proposed spot elevations represent finished pavement or ground surface grade unless otherwise noted on drawings.

4. Contractor shall submit for review to the District and District's engineer shop drawings on all precast and manufactured items to be used on this site. Failure to obtain approval before installation may result in removal and replacement at Contractor's expense. Engineer's approval of a shop drawing does not relieve the Contractor's responsibility for the performance of the item.

5. The cost of all testing of compaction and other required tests shall be paid by the Contractor and made available to the engineer of record during site inspections.

6. General Contractor to contact engineer of record and the District Representative 48 hours in advance prior to backfilling trenches for field inspection and prior to laying asphalt for field inspection.

7. Contractor is to submit FDOT approved asphalt design mixes to the District Representative and engineer of record before any work is to commence on project. The mixture at the plant or on the road shall not exceed 335 degrees. The Contractor shall notify the District Representative and provide temperature readings prior to laying asphalt.

8. As determined necessary and directed by the engineer of record, the Contract shall undercut all unsuitable material 24 inches below the bottom of any proposed limerock base, and shall backfill with fill material meeting FDOT standard specifications for road and bridge construction. See FDOT Index 120-001 and 120-002.
9. Provide level platform in front of all egress doors. The floor surface on both sides of a door shall be at the same elevation. The floor surface or landing on each side of the door shall extend from the door in the closed position a distance equal to the door width and shall comply with Section 4.13.6 Maneuvering Clearances at Doors of the Florida Accessibility Code for Building Construction.
10. Ramps shall have level landings at the bottom and top of each ramp run. Curb ramps are not required to have landings. Landings shall have the following features:
 - A. The landing shall be at least as wide as the ramp run leading to it.
 - B. All landings on ramp shall be not less than 60" clear, and the bottom of each ramp shall have not less than 72" of straight and level clearance.
 - C. If ramps change direction at landings, the minimum landing size shall be 60"x60". If a ramp run has a rise greater than 6" or a horizontal projection greater than 72" then it shall have handrails on both sides. Handrails are not required on curb ramps. Handrails shall be shown on the site plan.
11. The Contractor shall stockpile topsoil and construction materials in areas designated by the District.
12. The Contractor is responsible for providing record drawings as noted in Note #29 under Site General Notes.
13. All concrete used shall be 2,500 PSI minimum.
14. All wells, cleanouts, manhole tops, pull box covers and other utility appurtenances in the area of redevelopment shall be protected and tops adjusted to match proposed grades.
15. Contractor shall saw cut, tack, and match existing pavement at locations where new pavement meets any existing pavement.
16. Sod shall be placed around all structures as directed by the FDOT Index 524-001 and FDOT Index 425- and 430-Series as appropriate. All other disturbed areas shall be seeded and mulched.
17. All storm sewer curb and ditch bottom inlets shall conform to the applicable FDOT Index. All drainage structures with grades that are located in grassed areas shall have the grate chained to the structure using an eye bolt and chain.
18. All concrete structures shall have all exposed edges chamfered 3/4" and Class I surface finish.
19. All HDPE fittings and connectors shall be water tight. See Specifications for more information.
20. Compaction of all materials shall be limited to static mode only, unless directed otherwise by the engineer of record.
21. All RCP pipe joints shall be wrapped in with filter fabric in accordance with FDOT Standard Specification Section 430.

EROSION & SEDIMENTATION CONTROL

1. Silt fencing and/or staked haybales shall be constructed where shown on the drawings prior to starting construction.
2. All stormdrain inlets shall be protected during construction in accordance with FDOT State of Florida Erosion and Sediment Control Designer and Reviewer Manual.
3. The stormdrain system shall be flushed out to remove all accumulated debris and sediment upon completion of construction.
4. All disturbed areas in the construction area shall be completely stabilized by completion of construction. Grass seeding rates and mixtures shall be per Section 570 of the Standard Specifications. Evidence of growth must be present prior to final release.

ATTACHMENT C
FORM OF PROPOSAL
IFB 24-55
BHS STORMWATER DRAINAGE IMPROVEMENTS

Instructions: Having visited the site of the proposed project and familiarized themselves with all conditions affecting and governing the construction of said project, pricing bid shall be inclusive of all aspects of services required including: supervision; labor; technical expertise; equipment, tools, and trade accessories; fuel; transportation; travel time; insurance; profit; and, any other direct and indirect cost associated with the execution and administration of the contract and completion of the project, in full accordance with the contents of this IFB, and any addenda issued hereto. No additional costs, expenses or surcharges (i.e., mileage, fuel, travel time, etc.) shall be applicable to this contract unless specifically permitted herein.

BASE QUOTE: Figure: \$ _____
(Lump sum price)

ALLOWANCE: \$10,000, to be used at SBAC's discretion for unforeseen conditions.

Bidder is advised prior to submission of Bid to check the Purchasing Department website for any Addenda that may have been issued.

Bidder shall acknowledge receipt and acceptance of any addenda issued in the spaces provided below.

_____ Addendum No. 1
(initial here)

_____ Addendum No. 2
(initial here)

QUESTIONNAIRE:

Contact Information

Address of facility for which equipment/personnel shall be dispatched under this contract:

Firm Name: _____

Address: _____

City/State/Zip: _____

Contact Name: _____ Title: _____

Phone #: _____ Fax #: _____

Designated Account Representative:

Name: _____ Title: _____

Phone #: _____ Cell#: _____

Fax #: _____ Email: _____

Emergency Contact Information (if different then Account Representative):

Name: _____ Title: _____

Phone #: _____ Cell#: _____

Fax #: _____ Email: _____

Experience

- Years in business under present name: _____
- Year is which your firm was incorporated in the State of Florida: _____
- Years performing contract services in State of Florida: _____ Alachua County: _____

Business Operations

- Does your firm have the ability and experience to perform all services as described? Yes No
If no, list exceptions and provide explanation with Bid submittal.
- Is your firm in agreement to work after normal operating hours should request be made? Yes No
Exceptions: _____

- Does your firm have the capability to respond within forty-eight (48) hours of request should a non-emergency service work order be determined urgent by District? Yes No
- Does your firm have the capability to mobilize and respond within twenty-four (24) hours of notification in the event of an emergency? Yes No
- Is your business office staffed during regular business hours? Yes No
State regular business hours: _____ to _____

Personnel

- Current number of qualified Equipment Operators available under this contract: _____
- Current number of qualified General Laborers available under this contract: _____
- Current number of qualified Working Foremen available under this contract: _____

References

Provide five (05) references from commercial accounts or other public agencies within the State of Florida that your firm has provided site work project work within the past two (02) years. A minimum two (02) references shall be for a projects exceeding \$100,000.00.

1) Company/Organization name: _____

Address: _____ City/State/Zip: _____

Contact name: _____ Title: _____

Telephone #: (_____) _____ Under current contract: Yes No

Date last project completed: _____ Contract Amount: \$ _____

Description of services provided: _____

2) Company/Organization name: _____

Address: _____ City/State/Zip: _____

Contact name: _____ Title: _____

Telephone #: (_____) _____ Under current contract: Yes No

Date last project completed: _____ Contract Amount: \$ _____

Description of services provided: _____

3) Company/Organization name: _____

Address: _____ City/State/Zip: _____

Contact name: _____ Title: _____

Telephone #: (_____) _____ Under current contract: Yes No

Date last project completed: _____ Contract Amount: \$ _____

Description of services provided: _____

4) Company/Organization name: _____

Address: _____ City/State/Zip: _____

Contact name: _____ Title: _____

Telephone #: (_____) _____ Under current contract: Yes No

Date last project completed: _____ Contract Amount: \$ _____

Description of services provided: _____

5) Company/Organization name: _____

Address: _____ City/State/Zip: _____

Contact name: _____ Title: _____

Telephone #: (_____) _____ Under current contract: Yes No

Date last project completed: _____ Contract Amount: \$ _____

Description of services provided: _____

TOPOGRAPHIC SURVEY

LOCATED IN THE SW 1/4 OF SECTION 27, TOWNSHIP 9 SOUTH, RANGE 19 EAST,
ALACHUA COUNTY, FLORIDA

THIS IS NOT A BOUNDARY SURVEY

LEGEND:

- = BENCHMARK
- INV = INVERT
- N.R.E. = NORTH RIM ELEVATION
- HDPE = HIGH DENSITY POLYETHYLENE
- RCPP = REINFORCED CONCRETE PIPE
- PVC = POLYVINYL CHLORIDE
- CMP = CORRUGATED METAL PIPE
- NGVD = NATIONAL GEODETIC VERTICAL DATUM
- F.I.R.M. = FLOOD INSURANCE RATE MAP
- FEMA = FEDERAL EMERGENCY MANAGEMENT AGENCY (TYP) = TYPICAL
- X 165.5 = SPOT ELEVATION (PERVIOUS SURFACE)
- X 165.75 = SPOT ELEVATION (IMPERVIOUS SURFACE)
- ▲ WLPT 701-824 = WETLAND FLAGS
- = STORM SEWER MANHOLE
- = CATCH BASIN
- = BACKFLOW PREVENTOR
- = ELECTRIC BOX
- = ELECTRIC METER
- = GAS METER
- = TELEPHONE PEDESTAL
- = TRANSFORMER
- = METAL LIGHT POLE
- = WATER VALVE
- = WATER METER
- = CLEANOUT
- = FENCE (SIZE AND TYPE AS NOTED)
- = HAND RAIL
- = FEMA FLOODLINE (APPROXIMATE)
- = WETLAND LINE DELINEATED BY OTHERS
- = END OF FEATURE NOT DETERMINED
- = STORM SEWER LINE
- = CONTOUR LINE
- = ASPHALT SURFACE
- = CONCRETE SURFACE

SURVEYOR'S NOTES:

1. BEARINGS SHOWN HEREON ARE REFERRED TO A VALUE OF S 89°51'56" E FOR THE SOUTH LINE OF PLAT BOOK "O" PAGES 58-60 OF THE PUBLIC RECORDS OF ALACHUA COUNTY FLORIDA.
2. NO UNDERGROUND INSTALLATION OF UTILITIES OR IMPROVEMENTS HAVE BEEN LOCATED EXCEPT AS SHOWN. THE SURVEYOR MAKES NO GUARANTEE THAT THE UNDERGROUND UTILITIES SHOWN COMPRISE ALL SUCH UTILITIES IN THE AREA, EITHER IN SERVICE OR ABANDONED. THE SURVEYOR FURTHER DOES NOT WARRANT THAT THE UNDERGROUND UTILITIES SHOWN ARE IN THE EXACT LOCATION INDICATED ALTHOUGH HE DOES CERTIFY THAT THEY ARE LOCATED AS ACCURATELY AS POSSIBLE FROM INFORMATION AVAILABLE. THE SURVEYOR HAS NOT PHYSICALLY LOCATED THE UNDERGROUND UTILITIES.
3. THE SURVEYOR HAS NO KNOWLEDGE OF UNDERGROUND FOUNDATIONS WHICH MAY ENCROACH.
4. INSTRUMENTS OF RECORD REFLECTING EASEMENTS, RIGHTS-OF-WAY, AND OR OWNERSHIP WERE NOT FURNISHED TO THE SURVEYOR. SEARCH OF THE PUBLIC RECORDS HAS NOT BEEN DONE BY THE SURVEYOR.
5. THE PERIMETER LINES AND BOUNDARY CORNERS HAVE NOT BEEN LOCATED BY THIS SURVEYOR. THE BOUNDARY LINES SHOWN HEREON ARE FOR GRAPHICAL REFERENCE ONLY AND ARE APPROXIMATE.
6. INFORMATION FROM FEDERAL EMERGENCY MANAGEMENT AGENCY, (F.E.M.A.) FLOOD INSURANCE RATE MAP(S), SHOWN ON THIS MAP WAS CURRENT AS OF THE REFERENCED DATE. MAP REVISIONS AND AMENDMENTS ARE PERIODICALLY MADE BY LETTER AND MAY NOT BE REFLECTED ON THE MOST CURRENT MAP.
7. FENCES, SYMBOLS, MONUMENTATION AND UTILITIES SHOWN HEREON MAY BE EXAGGERATED FOR PICTORIAL PURPOSES ONLY AND MAY NOT BE SHOWN TO SCALE.
8. THE PURPOSE OF SURVEY IS TO SHOW EXISTING CONDITIONS OF THE PROJECT SITE DRAINAGE.
9. VERTICAL INFORMATION SHOWN HEREON IS REFERENCED TO THE NORTH AMERICAN VERTICAL DATUM OF 1988. SITE BENCHMARK SHOWN HEREON IS FROM CONSTRUCTION PLANS FOR THE BUCHHOLTZ HIGH SCHOOL TRACK BY DRMP, PROJECT NUMBER: 19-0381.091, DATED JUNE, 2021. ELEVATIONS SHOWN HEREON WERE DERIVED FROM SAID CONSTRUCTION PLANS.
10. ADDITIONAL POINTS MAY BE FOUND BY TURNING ON THE SV-NODE* LAYERS IN THE SUPPLIED DIGITAL FILE.
11. THIS SURVEY CONSISTS OF FOUR (4) SHEETS. ONE SHEET IS NOT CONSIDERED COMPLETE WITHOUT THE OTHERS.
12. WETLAND DELINEATION LINE MARKED BY OTHERS WITH MARKED LOCATIONS SURVEYED BY THIS OFFICE.
13. TOPOGRAPHY LIMITS ARE PER CLIENTS REQUEST.

FLOOD ZONE:

THIS PROPERTY IS LOCATED IN FEDERAL FLOOD ZONE "X". AREAS DETERMINED TO BE OUTSIDE THE 0.2% ANNUAL CHANCE FLOODPLAIN, AND IN FEDERAL FLOOD ZONE "A". AREAS SUBJECT TO INUNDATION BY THE 1% ANNUAL CHANCE FLOOD (NO BASE FLOOD ELEVATIONS DETERMINED) AS INTERPOLATED FROM F.I.R.M. PANEL NO. 12001C292D, EFFECTIVE DATE: JUNE 16, 2006.

SHEET 4

RICHMOND
(PLAT BOOK "O", PAGE 58)

S 89°51'56" E 659.66' (P)
(BASIS OF BEARINGS)

SHEET 3

S 0°08'17" W 332.34' (P)

BUCK RIDGE WEST
(PLAT BOOK "Y", PAGE 99)

S 89°58'42" E 659.48' (P)

BUCHHOLTZ HIGH SCHOOL

SHEET 2

SITE BENCHMARK
SET IRON ROD AND CAP STAMPED
"TRAVERSE LB 5075"
EL: 156.24'

SITE BENCHMARK
SET NAIL AND DISK STAMPED
"TRAV PT LB 5075"
EL: 168.70'

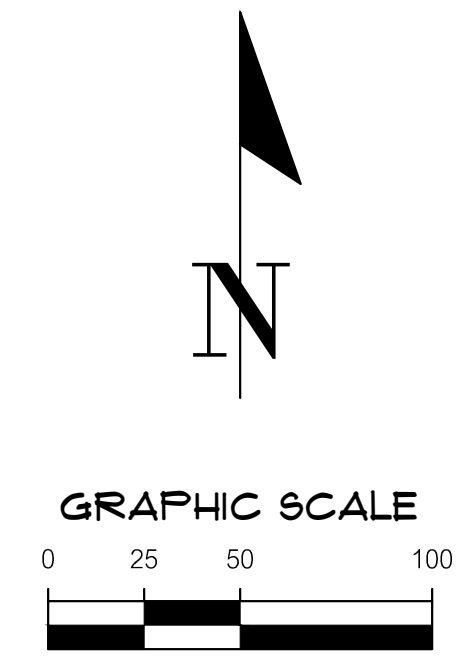

18001 Research Drive
Alachua, Florida 32915
(352) 331-1976
www.chw-inc.com
est. 1988 FLORIDA
CA-5075

CHW
Professional Consultants

SCALE: 1" = 50'
THIS SURVEY WAS MADE FROM ORIGINAL DRAWING. ANY REVISIONS TO THIS SHEET SHALL BE MADE BY THIS SURVEYOR. SCALES ACCORDINGLY.

ALACHUA COUNTY SCHOOL BOARD

REVISION DATE: 01-02-2024	ADDITIONAL TOPOGRAPHIC SURVEY	SHEET NO:	22-0241
DESIGNER: LUC	CHECKED BY: JAV	DATE: 01-02-2024	PROJECT NUMBER: 22-0241
DRAWN BY: JAV	CHECKED BY: AHH	DATE: 01-02-2024	PROJECT NUMBER: 22-0241
FIELD BOOK & PAGE: 6-47, 6-9			

AARON H. HICKMAN
Professional Surveyor & Mapper No. 61971

This map prepared by:
Certificate of Authorization No. LB-5075
NOT VALID WITHOUT THE ORIGINAL
SIGNATURE AND SEAL OR ELECTRONIC
DIGITAL SIGNATURE OF A FLORIDA
LICENSED SURVEYOR AND MAPPER

Title: www Post Date: Jan 04 2024 8:33am Filename: N:\2022\22-0241\Department\01_Survey\DWG\22-0241 Topographic Survey - BLS.dwg

SURVEYOR'S NOTES:

1. THIS SURVEY CONSISTS OF FOUR (4) SHEETS. ONE SHEET IS NOT CONSIDERED COMPLETE WITHOUT THE OTHERS. SEE SHEET ONE FOR ALL OTHER NOTES.

LEGEND:

- = BENCHMARK
- ▽ = INVERT
- N.R.E. = NORTH RIM ELEVATION
- HDPE = HIGH DENSITY POLYETHYLENE
- RCP = REINFORCED CONCRETE PIPE
- PVC = POLYVINYL CHLORIDE
- CMP = CORRUGATED METAL PIPE
- NGVD = NATIONAL GEODETIC VERTICAL DATUM
- F.I.R.M. = FLOOD INSURANCE RATE MAP
- FEMA = FEDERAL EMERGENCY MANAGEMENT AGENCY (TYP) = TYPICAL
- X 165.5 = SPOT ELEVATION (PERVIOUS SURFACE)
- X 165.75 = SPOT ELEVATION (IMPERVIOUS SURFACE)
- ▲ WLPT 701-824 = WETLAND FLAGS
- ⊕ = STORM SEWER MANHOLE
- ⊕ = CATCH BASIN
- ⊕ = BACKFLOW PREVENTOR
- ⊕ = ELECTRIC BOX
- ⊕ = ELECTRIC METER
- ⊕ = GAS METER
- ⊕ = TELEPHONE PEDESTAL
- ⊕ = TRANSFORMER
- ⊕ = METAL LIGHT POLE
- ⊕ = WATER VALVE
- ⊕ = WATER METER
- X — = FENCE (SIZE AND TYPE AS NOTED)
- ○ — = HAND RAIL
- · · · — = FEMA FLOODLINE (APPROXIMATE)
- · · · — = WETLAND LINE DELINEATED BY OTHERS
- · · · — = END OF FEATURE NOT DETERMINED
- ST — = STORM SEWER LINE
- — — = CONTOUR LINE
- ▭ = ASPHALT SURFACE
- ▭ = CONCRETE SURFACE

GRAPHIC SCALE

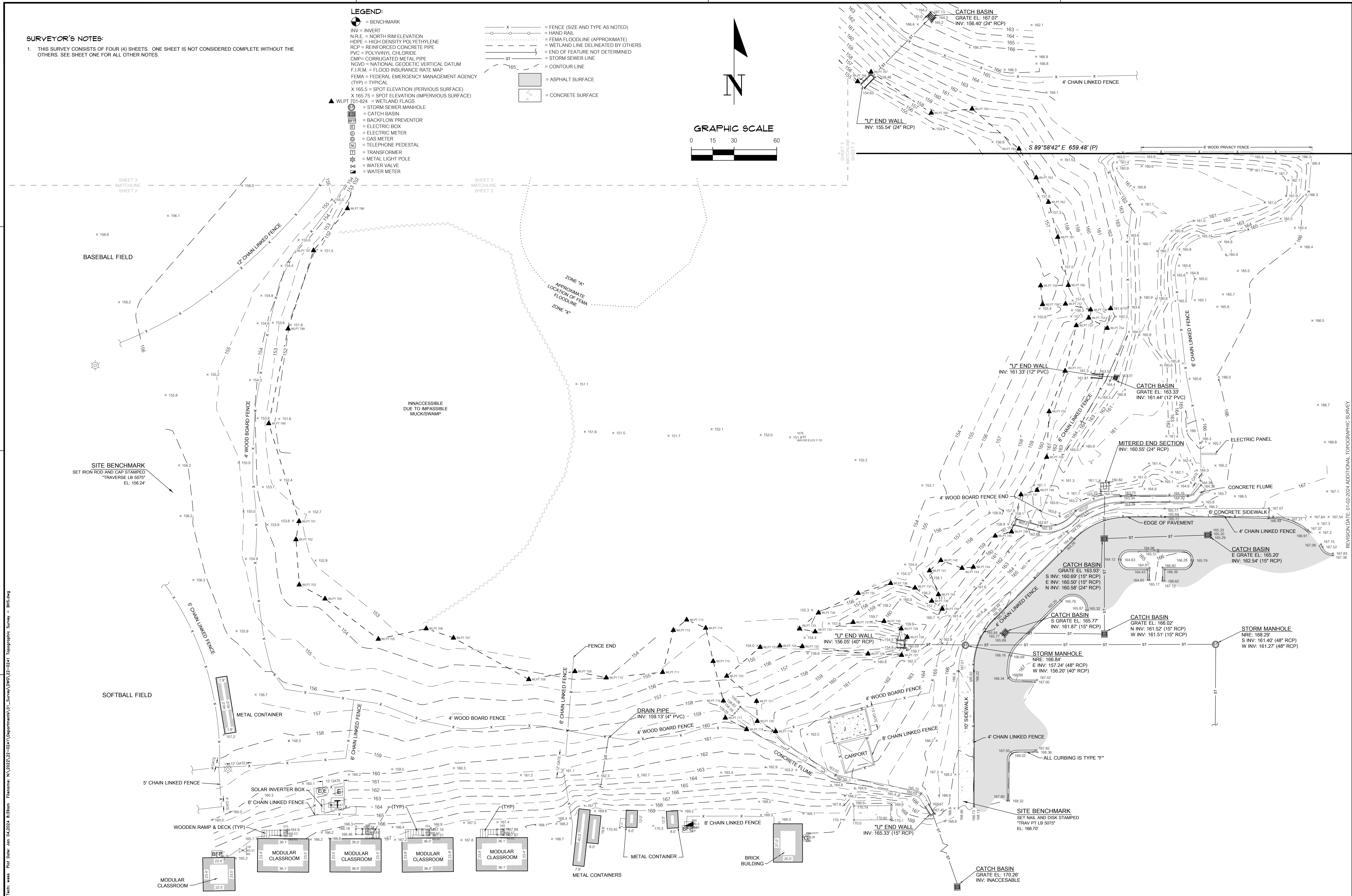
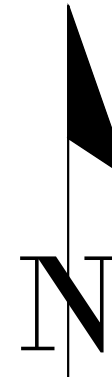
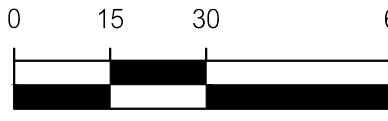

1801 Research Plus
Alachua, Florida 32015
(352) 331-9176
www.chw-inc.com
est. 1988 FLORIDA
CA-5075

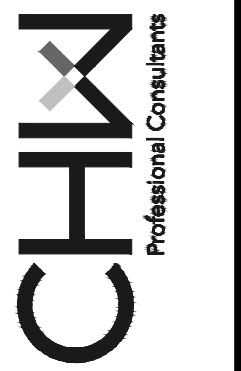

SCALE: 1" = 30'
REVISIONS:
DATE: 01-10-2024
BY: AHH
PROJECT NUMBER: 22-0241

SEE SHEET 1

REVISION	DATE	DESCRIPTION
1	07-08-2022	REVISED DATE 01-10-2024 ADDITIONAL TOPOGRAPHIC SURVEY
2	01-10-2024	REVISED DATE 01-10-2024 ADDITIONAL TOPOGRAPHIC SURVEY

SEE SHEET 1

This map prepared by:
Certificate of Authorization No. LB 5075
NOT VALID WITHOUT THE ORIGINAL
SIGNATURE AND SEAL OR ELECTRONIC
DIGITAL SIGNATURE OF A FLORIDA
LICENSED SURVEYOR AND MAPPER

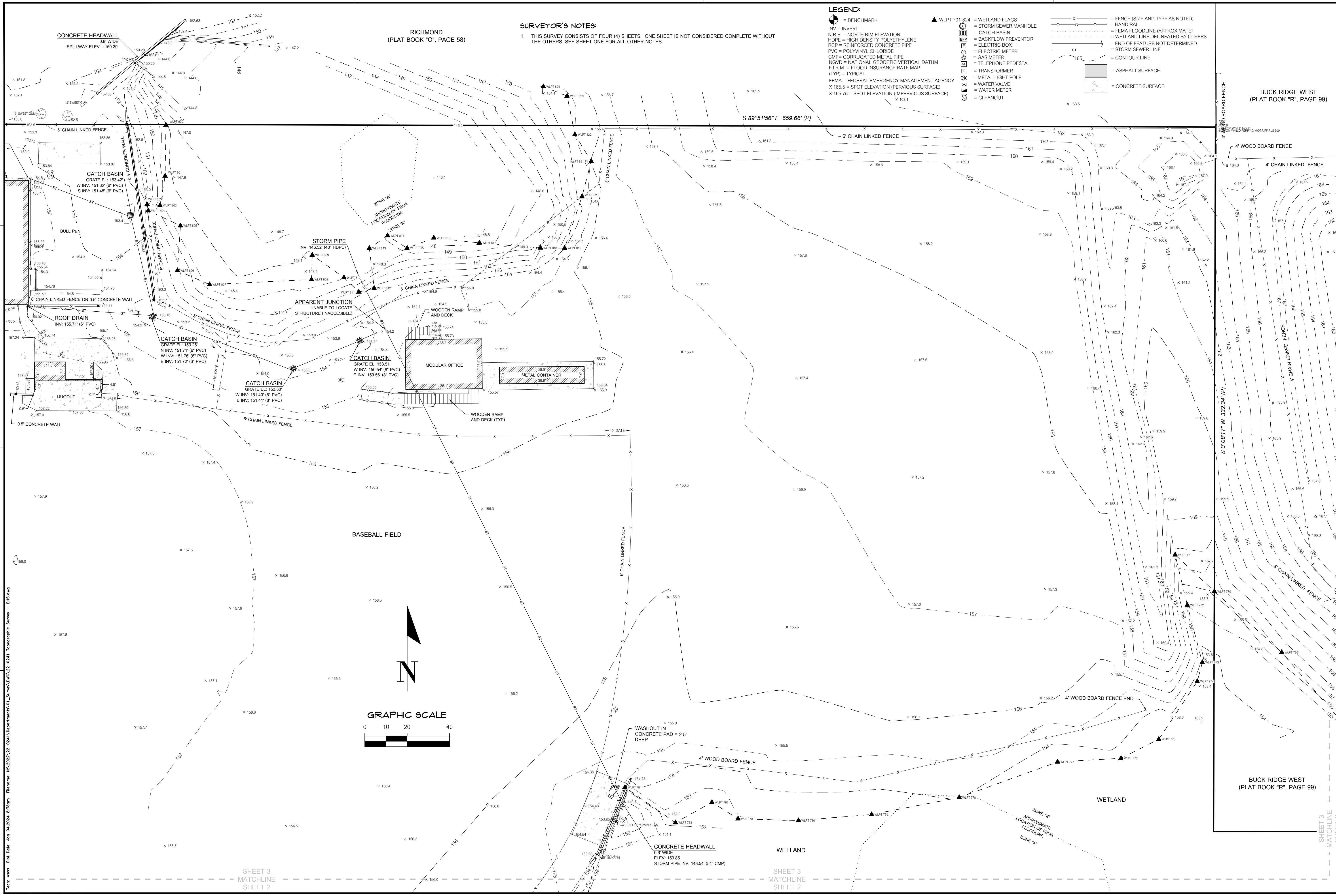

SURVEYOR'S NOTES:
 1. THIS SURVEY CONSISTS OF FOUR (4) SHEETS. ONE SHEET IS NOT CONSIDERED COMPLETE WITHOUT THE OTHERS. SEE SHEET ONE FOR ALL OTHER NOTES.

- LEGEND:**
- = BENCHMARK
 - INV = INVERT
 - N.R.E. = NORTH RIM ELEVATION
 - HDPE = HIGH DENSITY POLYETHYLENE
 - RCP = REINFORCED CONCRETE PIPE
 - PVC = POLYVINYL CHLORIDE
 - CMP = CORRUGATED METAL PIPE
 - NGVD = NATIONAL GEODETIC VERTICAL DATUM
 - F.I.R.M. = FLOOD INSURANCE RATE MAP
 - (TYP) = TYPICAL
 - FEMA = FEDERAL EMERGENCY MANAGEMENT AGENCY
 - X 165.5 = SPOT ELEVATION (PERVIOUS SURFACE)
 - X 165.75 = SPOT ELEVATION (IMPERVIOUS SURFACE)
 - ▲ WLPT 701-824 = WETLAND FLAGS
 - = STORM SEWER MANHOLE
 - = CATCH BASIN
 - = BACKFLOW PREVENTOR
 - = ELECTRIC BOX
 - = ELECTRIC METER
 - = GAS METER
 - = TELEPHONE PEDESTAL
 - = TRANSFORMER
 - = METAL LIGHT POLE
 - = WATER VALVE
 - = WATER METER
 - = CLEANOUT
 - X — = FENCE (SIZE AND TYPE AS NOTED)
 - ○ — = HAND RAIL
 - ○ — = FEMA FLOODLINE (APPROXIMATE)
 - ○ — = WETLAND LINE DELINEATED BY OTHERS
 - ○ — = END OF FEATURE NOT DETERMINED
 - ST — = STORM SEWER LINE
 - ○ — = CONTOUR LINE
 - = ASPHALT SURFACE
 - = CONCRETE SURFACE

RICHMOND
 (PLAT BOOK "O", PAGE 58)

BUCK RIDGE WEST
 (PLAT BOOK "R", PAGE 99)

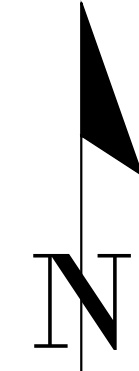
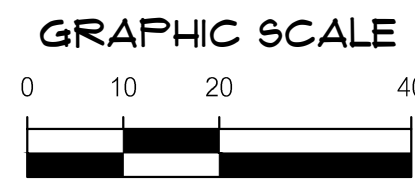

SHEET 3
 MATCHLINE
 SHEET 2

SHEET 3
 MATCHLINE
 SHEET 2

1801 Research Plus
 Alachua, Florida 32015
 (352) 331-9176
 www.chw-inc.com
 est. 1988 FLORIDA
 CA-5075

CHW
 Professional Consultants

REVISIONS SHALL BE MADE ON ORIGINAL DRAWING
 0. ANY REVISIONS MUST BE MADE ON THIS SHEET. ADJUST SCALES ACCORDINGLY.

SCALE: 1" = 20'

SEE SHEET 1

SURVEY DATE: 07-08-2022	REVISION DATE: 01-02-2024	PROJECT NUMBER: 22-0241	DRAWN BY: BBS
DESIGNED BY: BBS	CHECKED BY: AHH	FIELD BOOK & PAGE: 6-47, 6-9	

This map prepared by: _____
 Certificate of Authorization No. L.B. 5075
 NOT VALID WITHOUT THE ORIGINAL
 SIGNATURE AND SEAL OR ELECTRONIC
 DIGITAL SIGNATURE OF A FLORIDA
 LICENSED SURVEYOR AND MAPPER

SHEET NO.: 3 OF 4

SURVEYOR'S NOTES:

1. THIS SURVEY CONSISTS OF FOUR (4) SHEETS. ONE SHEET IS NOT CONSIDERED COMPLETE WITHOUT THE OTHERS. SEE SHEET ONE FOR ALL OTHER NOTES.

LEGEND:

- ⊕ = BENCHMARK
- INV = INVERT
- N.R.E. = NORTH RIM ELEVATION
- HDPE = HIGH DENSITY POLYETHYLENE
- RCP = REINFORCED CONCRETE PIPE
- PVC = POLYVINYL CHLORIDE
- CMP = CORRUGATED METAL PIPE
- NGVD = NATIONAL GEODETIC VERTICAL DATUM
- F.I.R.M. = FLOOD INSURANCE RATE MAP
- X 165.5 = SPOT ELEVATION (PERVIOUS SURFACE)
- X 165.75 = SPOT ELEVATION (IMPERVIOUS SURFACE)
- ▲ WLP1 701-824 = WETLAND FLAGS
- ⊗ = STORM SEWER MANHOLE
- ⊞ = CATCH BASIN
- ⊞ = BACKFLOW PREVENTOR
- ⊞ = ELECTRIC BOX
- ⊞ = ELECTRIC METER
- ⊞ = GAS METER
- ⊞ = TELEPHONE PEDESTAL
- ⊞ = TRANSFORMER
- ⊞ = METAL LIGHT POLE
- ⊞ = WATER VALVE
- ⊞ = WATER METER
- ⊞ = CLEANOUT
- ▭ = ASPHALT SURFACE
- ▭ = CONCRETE SURFACE
- X — = FENCE (SIZE AND TYPE AS NOTED)
- ○ — = HAND RAIL
- - - - - = FEMA FLOODLINE (APPROXIMATE)
- - - - - = WETLAND LINE DELINEATED BY OTHERS
- ST — = END OF FEATURE NOT DETERMINED
- ST — = STORM SEWER LINE
- - - - - 165.5 = CONTOUR LINE
- LO = LIVE OAK
- LAO = LAUREL OAK
- ⊗ = TREE (SIZE AND TYPE AS NOTED)

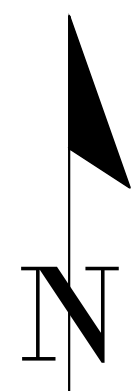

GRAPHIC SCALE

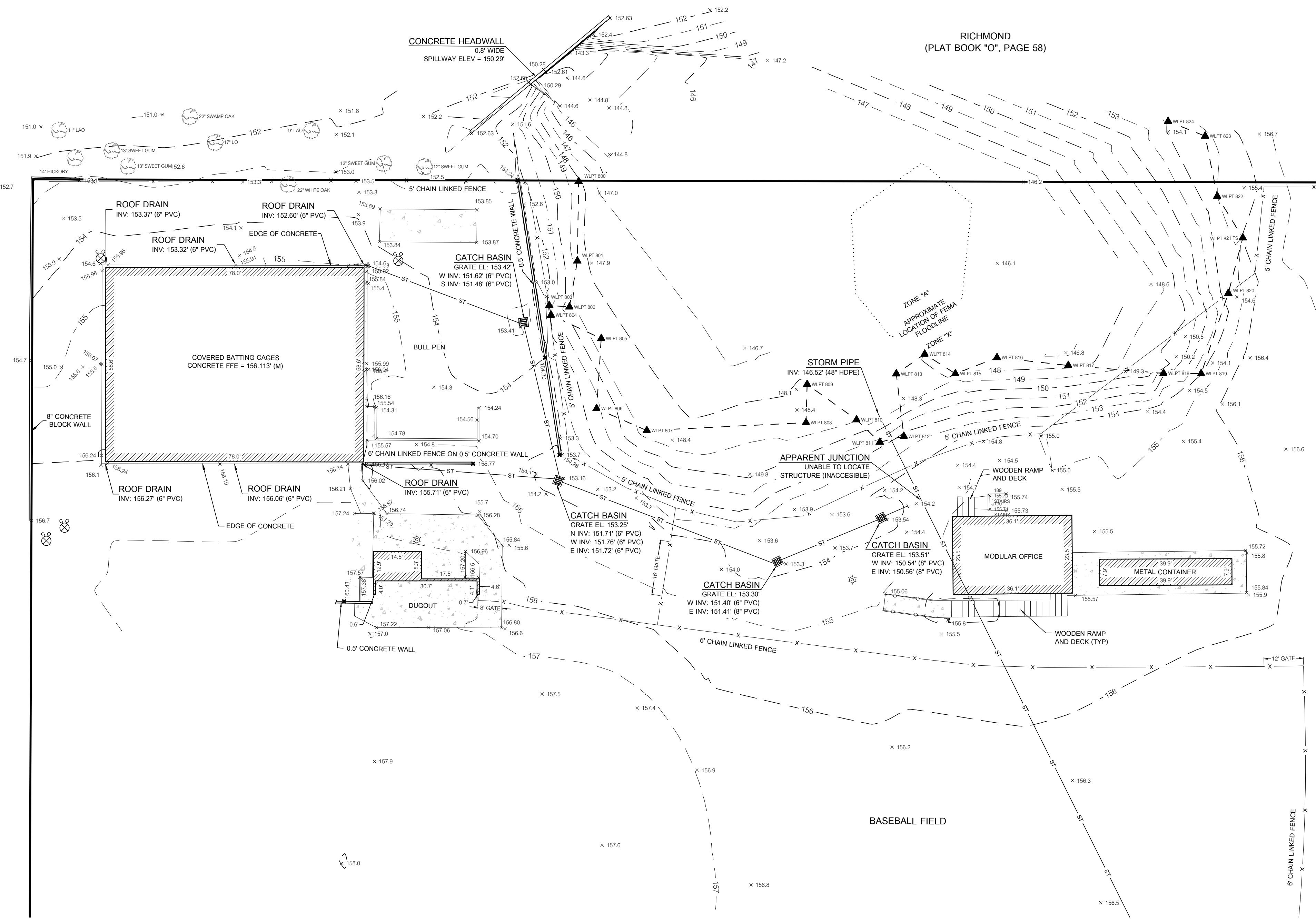

Text: wss Plot Date: Jan 04, 2024 8:45am Filename: N:\2022\22-0241\Department\01_Survey\DWG\22-0241 Topographic Survey - BBS.dwg

11801 Research Drive
Alachua, Florida 32915
(352) 331-1976
www.chw-inc.com
est. 1988 FLORIDA
CA-5075

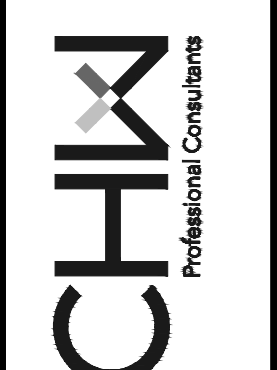

SCALE: 1" = 20'
REVISIONS SHALL BE MADE ON ORIGINAL DRAWING
0. ANY CHANGES MUST BE MADE ON THIS SHEET, ADJUST SCALES ACCORDINGLY.

REVISION DATE: 01-20-2024 ADDITIONAL TOPOGRAPHIC SURVEY
DATE: 07-08-2022
REVISION DATE: 01-10-2024
PROJECT NUMBER: 22-0241
SEE SHEET 1

DESIGNER: LUC/MES
DRAWN BY: JAV
CHECKED BY: AHH
FIELD BOOK & PAGE: 6-47, 6-9

SEE SHEET 1

This map prepared by:
Certificate of Authorization No. L.B. 5075
NOT VALID WITHOUT THE ORIGINAL
SIGNATURE AND SEAL OR ELECTRONIC
DIGITAL SIGNATURE OF A FLORIDA
LICENSED SURVEYOR AND MAPPER

GENERAL NOTES

1. THE TOPOGRAPHIC AND EXISTING INFORMATION SHOWN HEREON WERE TAKEN FROM A TOPOGRAPHIC SURVEY PREPARED BY CHW, AND DATED JULY 8, 2022 AND REVISED ON JANUARY 2, 2024.
2. THE LOCATION OF ALL EXISTING UTILITIES SHOWN ON THE PLANS HAS BEEN DETERMINED FROM THE BEST INFORMATION AVAILABLE. THE ENGINEER ASSUMES NO RESPONSIBILITY FOR ACCURACY. IT SHALL BE THE CONTRACTOR'S RESPONSIBILITY TO NOTIFY THE VARIOUS UTILITIES AND TO MAKE NECESSARY ARRANGEMENTS FOR ANY RELOCATION OF THESE UTILITIES WITH THE OWNER OF THE UTILITY. THE CONTRACTOR SHALL EXERCISE CAUTION WHEN CROSSING ANY UNDERGROUND UTILITY, WHETHER SHOWN ON THE PLANS OR LOCATED BY THE UTILITY COMPANY. THE RESPECTIVE UTILITY COMPANIES SHALL RELOCATE ALL UTILITIES THAT INTERFERE WITH THE PROPOSED CONSTRUCTION. THE CONTRACTOR SHALL COOPERATE WITH THE UTILITY COMPANIES DURING THE RELOCATION OPERATIONS. ANY DELAY OR INCONVENIENCE CAUSED TO THE CONTRACTOR BY THE VARIOUS UTILITIES SHALL BE INCIDENTAL TO THE CONTRACT AND NO EXTRA COMPENSATION WILL BE ALLOWED.
3. THE CONTRACTOR SHALL EXERCISE EXTREME CAUTION IN AREAS OF BURIED UTILITIES AND SHALL PROVIDE AT LEAST 48 HOURS NOTICE TO THE APPROPRIATE UTILITY COMPANIES IN ORDER TO ALLOW MARKING OF THE LOCATIONS OF EXISTING UNDERGROUND FACILITIES IN ADVANCE OF CONSTRUCTION BY CALLING THE FLORIDA SUNSHINE STATE ONE-CALL CENTER, INC. AT 1-800-432-4770 OR 811. IT IS THE CONTRACTOR'S RESPONSIBILITY TO NOTIFY "SUNSHINE" 48 HOURS PRIOR TO ANY CLEARING OF CONSTRUCTION TO IDENTIFY ALL UTILITY LOCATIONS. NO CONSTRUCTION ACTIVITY MAY OCCUR UNTIL THE UTILITIES HAVE BEEN PROPERLY MARKED.
4. THE CONTRACTOR SHALL FIELD VERIFY THE HORIZONTAL LOCATION AND VERTICAL LOCATION OF ALL EXISTING UTILITIES WITHIN THE LIMITS OF THE PROJECT ENVELOPE SHOWN PRIOR TO COMMENCING WORK. THE CONTRACTOR SHALL CALL ALL UTILITY COMPANIES TO HAVE THE LOCATIONS OF ALL UTILITIES FIELD MARKED PRIOR TO COMMENCEMENT OF CONSTRUCTION. ANY DISCREPANCIES SHALL BE BROUGHT TO THE ATTENTION OF THE ENGINEER PRIOR TO CONTINUING CONSTRUCTION.
5. THE CONTRACTOR IS RESPONSIBLE FOR REPAIRING ANY DAMAGE TO EXISTING FACILITIES, ABOVE OR BELOW GROUND THAT MAY OCCUR AS A RESULT OF THE WORK PERFORMED BY THE CONTRACTOR.
6. ALL PRIVATE AND PUBLIC PROPERTY AFFECTED BY THIS WORK SHALL BE RESTORED TO A CONDITION EQUAL TO OR BETTER THAN EXISTING CONDITIONS BEFORE COMMENCING CONSTRUCTION WORK, UNLESS SPECIFICALLY EXEMPTED BY THE PLANS. ADDITIONAL COSTS ARE INCIDENTAL TO OTHER CONSTRUCTION AND NO EXTRA COMPENSATION WILL BE ALLOWED.
7. ALL WORK PERFORMED SHALL COMPLY WITH THE REGULATIONS AND ORDINANCES OF THE VARIOUS GOVERNMENTAL AGENCIES HAVING JURISDICTION OVER THE WORK INCLUDING LANDSCAPING.
8. IT IS THE CONTRACTOR'S RESPONSIBILITY TO BECOME FAMILIAR WITH THE PERMIT AND INSPECTION REQUIREMENTS OF THE VARIOUS GOVERNMENTAL AGENCIES. THE CONTRACTOR SHALL OBTAIN ALL NECESSARY PERMITS PRIOR TO CONSTRUCTION AND SCHEDULE INSPECTIONS ACCORDING TO AGENCY AND/OR MUNICIPALITY INSTRUCTIONS.
9. IT SHALL BE THE SOLE RESPONSIBILITY OF THE CONTRACTOR TO COMPLY WITH AND ENFORCE ALL APPLICABLE SAFETY REGULATIONS.
10. THE CONTRACTOR SHALL BE RESPONSIBLE FOR PROTECTING EXCAVATIONS AGAINST COLLAPSE AND SHALL PROVIDE BRACING, SHEETING OR SHORING AS NECESSARY. TRENCHES SHALL BE KEPT DRY WHILE PIPES ARE BEING PLACED. DEWATERING SHALL BE USED AS REQUIRED, AND PERMITTED THROUGH LOCAL GOVERNMENTAL AGENCIES AND WATER MANAGEMENT DISTRICT PER CURRENT REGULATIONS AT THE SOLE COST OF THE CONTRACTOR.
11. CONTRACTOR TO REVIEW GEOTECHNICAL REPORT AND BORINGS PRIOR TO BIDDING THE PROJECT AND FOLLOW OUTLINED CONSTRUCTION TECHNIQUES.
12. THE CONTRACTOR IS RESPONSIBLE FOR COORDINATING APPLICABLE TESTING WITH THE SERVICES OF AN APPROVED TESTING LABORATORY AND/OR SOILS ENGINEER, APPLICABLE REGULATORY AGENCIES, AND AS MAY BE FOUND IN THE ENGINEERING CONSTRUCTION DRAWINGS OR SPECIFICATIONS. CONTRACTOR TO VERIFY ALL TESTING WITH THE OWNER PRIOR TO COMMENCING CONSTRUCTION. UPON COMPLETION OF THE WORK, THE TESTING LABORATORY AND/OR SOILS ENGINEER MUST SUBMIT TO THE OWNER'S ENGINEER CERTIFICATIONS STATING THAT ALL REQUIREMENTS HAVE BEEN MET.
13. INSTALL SILT FENCE PRIOR TO SITE DEMOLITION OR NEW SITE CONSTRUCTION. INSTALL SILT FENCE PER FLORIDA STORMWATER EROSION AND SEDIMENTATION CONTROL INSPECTOR'S MANUAL AND PROVIDE TOE-IN. THE CONTRACTOR SHALL MAINTAIN THE SILT FENCE IN WORKING ORDER THROUGHOUT THE CONSTRUCTION PHASE. THE PROJECT SILT FENCE SHALL BE INSPECTED DAILY AND ANY CORRECTIVE MEASURES SHALL BE COMPLETED WITHIN 24 HOURS.
14. ALL TREE BARRICADES AND SILT FENCING SHALL BE INSTALLED AND INSPECTED BY ALACHUA COUNTY SCHOOL BOARD REPRESENTATIVE PRIOR TO COMMENCEMENT OF ANY DEMOLITION OR CONSTRUCTION ACTIVITIES.
15. THE CONTRACTOR IS TO PREPARE THE SITE PRIOR TO BEGINNING ACTUAL CONSTRUCTION IN ACCORDANCE WITH THE GEOTECHNICAL REPORT.
16. ALL DELETERIOUS MATERIAL (I.E. MUCK, PEAT, BURIED DEBRIS) IS TO BE EXCAVATED IN ACCORDANCE WITH THESE PLANS OR AS DIRECTED BY THE OWNER'S ENGINEER OR OWNER'S SOIL TESTING COMPANY. DELETERIOUS MATERIAL IS TO BE STOCKPILED AND REMOVED FROM THE SITE. EXCAVATED AREAS ARE TO BE BACKFILLED WITH APPROVED MATERIALS AND COMPACTED AS SHOWN ON THESE AREAS.
17. CONTRACTOR SHALL CLEAR AND GRUB ONLY THOSE PORTIONS OF THE SITE NECESSARY FOR CONSTRUCTION. DISTURBED AREAS SHALL BE SODDED, SEEDED, MULCHED, OR PLANTED WITH OTHER APPROVED LANDSCAPE MATERIAL, AS DIRECTED BY THESE PLANS, IMMEDIATELY FOLLOWING CONSTRUCTION PER LOCAL INSPECTOR.
18. WORK BEING PERFORMED UNDER THIS CONTRACT SHALL INTERFACE SMOOTHLY WITH OTHER WORK BEING PERFORMED ON THE SITE BY OTHER CONTRACTORS AND/OR UTILITY COMPANIES. IT WILL BE NECESSARY FOR THE CONTRACTOR TO COORDINATE AND SCHEDULE HIS ACTIVITIES, WHERE NECESSARY, WITH OTHER CONTRACTORS AND UTILITY COMPANIES.
19. ALL PAVEMENT DIMENSIONS SHOWN ARE TO EDGE OF PAVEMENT UNLESS OTHERWISE NOTED.
20. THE GOVERNING STANDARDS AND SPECIFICATIONS, UNLESS STATED OTHERWISE SHALL BE PER FLORIDA DEPARTMENT OF TRANSPORTATION STANDARD PLANS (FY 2023-24 ROAD CONSTRUCTION), AND STANDARD SPECIFICATIONS FOR ROAD AND BRIDGE CONSTRUCTION DATED JANUARY 2018, AS AMENDED BY CONTRACT DOCUMENTS. ALL MATERIALS AND METHODS SHALL MEET FDOT STANDARD SPECIFICATIONS AND SHALL BE PRODUCED OR OBTAINED FROM AN FDOT APPROVED SOURCE.
21. ALL NEW TRAFFIC CONTROL DEVICES (SIGNS AND PAVEMENT MARKINGS) SHALL CONFORM TO THE MANUAL ON UNIFORM TRAFFIC CONTROL DEVICES (MUTCD) AND FDOT STANDARDS.
22. ALL STRIPING WITHIN THE FDOT RIGHT OF WAY SHALL BE PLACED FIRST AS TEMPORARY STRIPING FOLLOWED BY APPLICATION OF THERMOPLASTIC STRIPING 30 DAYS LATER.
23. CONTRACTOR IS RESPONSIBLE FOR MAINTAINING PROPER BENCHMARKS ON-SITE. EXISTING BENCH MARKS SCHEDULED FOR REMOVAL SHALL BE RELOCATED AT CONTRACTORS EXPENSE AND RE-ESTABLISHED BY A LICENSED SURVEYOR.
24. ALL HANDICAP RAMPS SHALL COMPLY WITH THE FLORIDA ACCESSIBILITY CODE AND AMERICANS WITH DISABILITIES ACT.
25. A PRE-CONSTRUCTION CONFERENCE SHALL BE REQUIRED. THE CONTRACTOR, ENGINEER OF RECORD, AND THE OWNER SHALL MEET WITH THE ALACHUA SCHOOL BOARD REPRESENTATIVE PRIOR TO INITIATION OF SITE CONSTRUCTION.
26. ANY CHANGE ORDER REQUESTS, SITE REVISIONS, AND PAY REQUESTS MUST BE SUBMITTED TO AND APPROVED BY THE ENGINEER OF RECORD.
27. CONTRACTOR IS RESPONSIBLE FOR ALL DEWATERING AS NEEDED THROUGHOUT ALL CONSTRUCTION ACTIVITIES COVERED BY THESE PLANS. DEWATERING SHALL BE DONE IN ACCORDANCE WITH FDOT STANDARD SPECIFICATIONS, 2018 EDITION, SECTION 120.
28. THE CONTRACTOR IS RESPONSIBLE FOR THE PERFORMANCE AND COST OF ALL CLEARING AND GRUBBING AND ALL WORK OF REMOVAL, DISPOSAL, AND REPAIR OR REPLACEMENT OF EXISTING IMPROVEMENTS HERE SHOWN IN THE PLANS, OR ORDERED BY THE ENGINEER TO BE REMOVED, OR WHERE REQUIRED BECAUSE OF THE CONSTRUCTION OPERATIONS, IN ORDER TO CONSTRUCT THE PROPOSED IMPROVEMENTS (THIS INCLUDES BUT IS NOT LIMITED TO PROPOSED PIPING, STRUCTURES, UTILITIES, PAVING, CURBING, ETC.).
29. AN AS-BUILT SURVEY MAY BE REQUIRED BY REGULATORY AGENCIES. CONTRACTOR TO COORDINATE WITH PROJECT OWNER FOR COMPLETION OF AS-BUILT SURVEYS PRIOR TO PROJECT / PERMIT CLOSE-OUT.

DEMOLITION GENERAL NOTES

1. THE CONTRACTOR SHALL BE RESPONSIBLE TO DISPOSE OF ALL DEMOLITION MATERIALS IN A SAFE AND LAWFUL MANNER. THE CONTRACTOR SHALL SALVAGE TO THE OWNER ANY ITEM AS DETERMINED BY THE OWNER. ONCE DEMOLISHED, MATERIAL SHALL BE DISPOSED OF PROPERLY AND IMMEDIATELY.
2. REMOVE ALL IMPROVEMENTS DEFINED ON THE DEMOLITION PLAN. SALVAGE ITEMS TO OWNER AS DEFINED BY THE OWNER'S REPRESENTATIVE AND CONSTRUCTION DOCUMENT SPECIFICATIONS.
3. EXISTING PAVEMENT AND SIDEWALK EDGES THAT BORDER NEW CONSTRUCTION OR DEMOLITION ARE TO BE SAW-CUT TO PROVIDE A SMOOTH TRANSITION.
4. ALL EXISTING TREES ARE TO REMAIN UNLESS OTHERWISE NOTED.
5. ROOTS LARGER THAN 1 INCH IN DIAMETER ON TREES TO BE PRESERVED THAT ARE ENCOUNTERED DURING CONSTRUCTION MUST BE CUT CLEANLY AND COVERED OVER WITH SOIL BY THE END OF THE WORKING DAY.
6. ALL ASPHALT AND LIMEROCK WILL BE COMPLETELY REMOVED FROM AREAS THAT WILL BE LANDSCAPED. IN PARTICULAR, AREAS WHERE ASPHALT WILL BE REMOVED MUST HAVE THE TOP HARD SURFACE, LIMEROCK, AND COMPACTED SOIL REMOVED. REPLACEMENT SOIL SHALL BE CLEAN DEEP FILL OF PH 5.5 - 6.5. THE DEPTH OF UNCOMPACTED SOIL PRIOR TO PLANTING MUST BE AT LEAST 3 FEET TO ACCOMMODATE FUTURE TREE ROOT GROWTH. NO LIMEROCK, LARGE STONES, OR OTHER CONSTRUCTION DEBRIS CAN REMAIN IN AREAS TO BE LANDSCAPED.

PAVING, GRADING, AND DRAINAGE GENERAL NOTES

1. THE CONTRACTOR IS RESPONSIBLE FOR EROSION/SEDIMENTATION CONTROL PRACTICES DURING CONSTRUCTION TO MINIMIZE ON-SITE EROSION/SEDIMENTATION AND TO PROTECT AGAINST DAMAGE TO OFF SITE PROPERTY. THE FOLLOWING PRACTICES SHALL BE EMPLOYED:
 - A. EROSION AND SEDIMENTATION CONTROL SHALL BE THE RESPONSIBILITY OF THE CONTRACTOR. AREAS OF OFF-SITE DISCHARGE DURING CONSTRUCTION SHALL BE PROTECTED WITH A SEDIMENT BARRIER PER FLORIDA STORMWATER EROSION AND SEDIMENTATION CONTROL INSPECTOR'S MANUAL TO PREVENT OFF-SITE DISCHARGE OF SEDIMENTS. A SILT BARRIER SHALL SPECIFICALLY BE REQUIRED, CONSTRUCTED, AND MAINTAINED AS INDICATED ON THIS SHEET. TEMPORARY SEED AND MULCH SHOULD BE USED TO CONTROL ON-SITE EROSION WHEN IT IS NOT PRACTICAL TO ESTABLISH PERMANENT VEGETATION. SOD SHALL BE PLACED AS EARLY AS POSSIBLE ON ALL SLOPES STEEPER THAN 5 (FT) HORIZONTAL TO 1 (FT) VERTICAL. SOD SHALL BE PINNED AS REQUIRED. ALL EROSION AND SEDIMENTATION CONTROL MEASURES SHALL BE MAINTAINED IN WORKING ORDER THROUGHOUT THE CONSTRUCTION PHASE. THE CONTRACTOR SHALL INSPECT AND REPAIR AS NECESSARY THE EROSION/SEDIMENTATION PROTECTION AT THE END OF EACH WORKING DAY.
 - B. NOTE: EROSION/SEDIMENTATION CONTROL SHALL BE PLACED PRIOR TO SITE EXCAVATION AND SHALL REMAIN IN PLACE UNTIL SITE VEGETATION AND LANDSCAPING IS COMPLETE.
 - C. B. ALL INLET STRUCTURES AND PIPE SHALL BE PROTECTED FROM SILTATION BY CONSTRUCTING INLET PROTECTION AS DEFINED BY THESE PLANS OR IN THE FDOT STANDARDS. IF SILTATION OCCURS, THE CONTRACTOR IS RESPONSIBLE TO REMOVE SILTATION AS PART OF THE BASE CONTRACT AT NO ADDITIONAL COST TO THE OWNER.
 - D. C. EXCAVATED STORMWATER FACILITIES SHALL BE CONSTRUCTED AS PART OF THE INITIAL CONSTRUCTION. THE FACILITIES SHALL BE ROUGH GRADED TO THE DESIGN ELEVATIONS. AFTER THE CONTRIBUTING DRAINAGE AREA IS STABILIZED, THE FACILITIES BOTTOM SHALL BE OVER EXCAVATED BY SIX INCHES, SCARIFIED, BACKFILLED WITH ARCHER FILL (HAVING NO MORE THAN 5% PASSING NO. 200 SIEVE) AND GRADED TO FINAL DESIGN GRADES. EXCESS AND UNSUITABLE SOILS SHALL BE REMOVED FROM THE BASIN (REMOVE ALL ACCUMULATED SILTS, CLAYS, ORGANIC, AND DEBRIS). FINALLY, SCARIFY AND RAKE BOTTOM AND VEGETATE.
 - E. D. PERMANENT VEGETATIVE STABILIZATION SHALL BE APPLIED ON FINE GRADED SITES AS SOON AS PRACTICAL. TEMPORARY SEEDING SHOULD BE EMPLOYED TO PREVENT EXPOSURE OF BARREN SOILS UNTIL PERMANENT VEGETATION CAN BE APPLIED.
 - F. E. ALL SLOPES 1:3 OR STEEPER REQUIRE LAPPED OR PEGGED SOD.
 - G. F. EROSION, SEDIMENT AND TURBIDITY CONTROL ARE THE RESPONSIBILITY OF THE CONTRACTOR. THESE DELINEATED MEASURES ARE THE MINIMUM REQUIRED, WITH ADDITIONAL CONTROLS TO BE UTILIZED AS NEEDED, DEPENDENT UPON ACTUAL SITE CONDITIONS AND CONSTRUCTION OPERATION.
 - H. G. ALL SYNTHETIC BALES, SILT FENCE, AND OTHER EROSION CONTROL MEASURES SHALL BE REMOVED AT THE COMPLETION OF THE PROJECT.
2. THE CONTRACTOR SHALL MAINTAIN IN HIS POSSESSION A COPY OF THE WATER MANAGEMENT DISTRICT CONSTRUCTION PERMIT. HE SHALL BE RESPONSIBLE FOR ADHERENCE TO ALL CONDITIONS CONTAINED IN THE PERMIT.
3. PROPOSED SPOT ELEVATIONS REPRESENT FINISHED PAVEMENT OR GROUND SURFACE GRADE UNLESS OTHERWISE NOTED ON DRAWINGS.
4. CONTRACTOR SHALL SUBMIT FOR REVIEW TO THE OWNER AND OWNER'S ENGINEER SHOP DRAWINGS ON ALL PRECAST AND MANUFACTURED ITEMS TO BE USED ON THIS SITE. FAILURE TO OBTAIN APPROVAL BEFORE INSTALLATION MAY RESULT IN REMOVAL AND REPLACEMENT AT CONTRACTOR'S EXPENSE. ENGINEER'S APPROVAL OF A SHOP DRAWING DOES NOT RELIEVE THE CONTRACTOR'S RESPONSIBILITY FOR THE PERFORMANCE OF THE ITEM.
5. THE COST OF ALL TESTING OF COMPACTION AND OTHER REQUIRED TESTS SHALL BE PAID BY THE CONTRACTOR AND MADE AVAILABLE TO THE ENGINEER OF RECORD DURING SITE INSPECTIONS.
6. GENERAL CONTRACTOR TO CONTACT ENGINEER OF RECORD AND THE OWNER REPRESENTATIVE 48 HOURS IN ADVANCE PRIOR TO BACKFILLING TRENCHES FOR FIELD INSPECTION AND PRIOR TO LAYING ASPHALT FOR FIELD INSPECTION.
7. CONTRACTOR IS TO SUBMIT FDOT APPROVED ASPHALT DESIGN MIXES TO THE OWNER'S REPRESENTATIVE AND ENGINEER OF RECORD BEFORE ANY WORK IS TO COMMENCE ON PROJECT. THE MIXTURE AT THE PLANT OR ON THE ROAD SHALL NOT EXCEED 3% DEGREES. THE CONTRACTOR SHALL NOTIFY THE OWNER'S REPRESENTATIVE AND PROVIDE TEMPERATURE READINGS PRIOR TO LAYING ASPHALT.
8. AS DETERMINED NECESSARY AND DIRECTED BY THE ENGINEER OF RECORD, THE CONTRACTOR SHALL UNDERCUT ALL UNSUITABLE MATERIAL 24 INCHES BELOW THE BOTTOM OF ANY PROPOSED LIMEROCK BASE, AND SHALL BACKFILL WITH FILL MATERIAL MEETING FDOT STANDARD SPECIFICATIONS FOR ROAD AND BRIDGE CONSTRUCTION. SEE FDOT INDEX 120-001 AND 120-002.
9. PROVIDE LEVEL PLATFORM IN FRONT OF ALL EGRESS DOORS. THE FLOOR SURFACE ON BOTH SIDES OF A DOOR SHALL BE AT THE SAME ELEVATION. THE FLOOR SURFACE OR LANDING ON EACH SIDE OF THE DOOR SHALL EXTEND FROM THE DOOR IN THE CLOSED POSITION A DISTANCE EQUAL TO THE DOOR WIDTH AND SHALL COMPLY WITH SECTION 4.13.6 MANEUVERING CLEARANCES AT DOORS OF THE FLORIDA ACCESSIBILITY CODE FOR BUILDING CONSTRUCTION.
10. RAMPS SHALL HAVE LEVEL LANDINGS AT THE BOTTOM AND TOP OF EACH RAMP RUN. CURB RAMPS ARE NOT REQUIRED TO HAVE LANDINGS. LANDINGS SHALL HAVE THE FOLLOWING FEATURES:
 - A. THE LANDING SHALL BE AT LEAST AS WIDE AS THE RAMP RUN LEADING TO IT.
 - B. ALL LANDINGS ON RAMPS SHALL BE NOT LESS THAN 60" CLEAR, AND THE BOTTOM OF EACH RAMP SHALL HAVE NOT LESS THAN 72" OF STRAIGHT AND LEVEL CLEARANCE.
 - C. IF RAMPS CHANGE DIRECTION AT LANDINGS, THE MINIMUM LANDING SIZE SHALL BE 60"x60". IF A RAMP RUN HAS A RISE GREATER THAN 6" OR A HORIZONTAL PROJECTION GREATER THAN 72" THEN IT SHALL HAVE HANDRAILS ON BOTH SIDES. HANDRAILS ARE NOT REQUIRED ON CURB RAMPS. HANDRAILS SHALL BE SHOWN ON THE SITE PLAN.
11. THE CONTRACTOR SHALL STOCKPILE TOPSOIL AND CONSTRUCTION MATERIALS IN AREAS DESIGNATED BY THE OWNER.
12. THE CONTRACTOR IS RESPONSIBLE FOR PROVIDING RECORD DRAWINGS AS NOTED IN NOTE #29 UNDER SITE GENERAL NOTES.
13. ALL CONCRETE USED SHALL BE 2,500 PSI MINIMUM.
14. ALL WELLS, CLEANOUTS, MANHOLE TOPS, PULL BOX COVERS AND OTHER UTILITY APPURTENANCES IN THE AREA OF REDEVELOPMENT SHALL BE PROTECTED AND TOPS ADJUSTED TO MATCH PROPOSED GRADES.
15. CONTRACTOR SHALL SAW CUT, TACK, AND MATCH EXISTING PAVEMENT AT LOCATIONS WHERE NEW PAVEMENT MEETS ANY EXISTING PAVEMENT.
16. SOD SHALL BE PLACED AROUND ALL STRUCTURES AS DIRECTED BY THE FDOT INDEX 524-001 AND FDOT INDEX 425- AND 430- SERIES AS APPROPRIATE. ALL OTHER DISTURBED AREAS SHALL BE SEEDED AND MULCHED.
17. ALL STORM SEWER CURB AND DITCH BOTTOM INLETS SHALL CONFORM TO THE APPLICABLE FDOT INDEX. ALL DRAINAGE STRUCTURES WITH GRATES THAT ARE LOCATED IN GRASSED AREAS SHALL HAVE THE GRATE CHAINED TO THE STRUCTURE USING AN EYE BOLT AND CHAIN.
18. ALL CONCRETE STRUCTURES SHALL HAVE ALL EXPOSED EDGES CHAMFERED 3/4" AND CLASS 1 SURFACE FINISH.
19. ALL HDPE FITTINGS AND CONNECTORS SHALL BE WATER TIGHT. SEE SPECIFICATIONS FOR MORE INFORMATION.
20. COMPACTION OF ALL MATERIALS SHALL BE LIMITED TO STATIC MODE ONLY, UNLESS DIRECTED OTHERWISE BY THE ENGINEER OF RECORD.
21. ALL RCP PIPE JOINTS SHALL BE WRAPPED WITH FILTER FABRIC IN ACCORDANCE WITH FDOT STANDARD SPECIFICATION SECTION 430.

File Name: N:\2024\22-0241\Department\04_Engineering\02_DWG\Bidding\Copies\Production\Task\22-0241-02.dwg
Title: gabriela
Plot Date: Apr 08 2024 11:45am

11801 Research Drive
Alachua, Florida 32615
(352) 351-1976
www.chw-inc.com
est. 1988 FLORIDA
CA-5075

CHW
Professional Consultants

SCALE: N/A
VERIFY ALL FIELD DATA ON ORIGINAL DRAWING
IF ANY FIELD CONDITIONS DIFFER FROM THIS SHEET, ADJUST SCALES ACCORDINGLY.

CONSTRUCTION PERMIT NO.

ALACHUA COUNTY PUBLIC SCHOOLS
BICHOLZ HIGH SCHOOL BATTING CAGE DRAINAGE
COUNTY

02/20/2024 SHIMWD
04/08/2024 BID DOCUMENTS, SCHOOL BOARD OF ALACHUA COUNTY

DESIGNED BY: K.T. MCMAHON
CHECKED BY: G. LEFORD, E.I.
QUALITY CONTROL: W. OWEN, P.E.
PROJECT NUMBER: 22-0241

WALKER FAIRN OWEN, PE

FL PE No. 94201

SHEET NO. **C0.10**

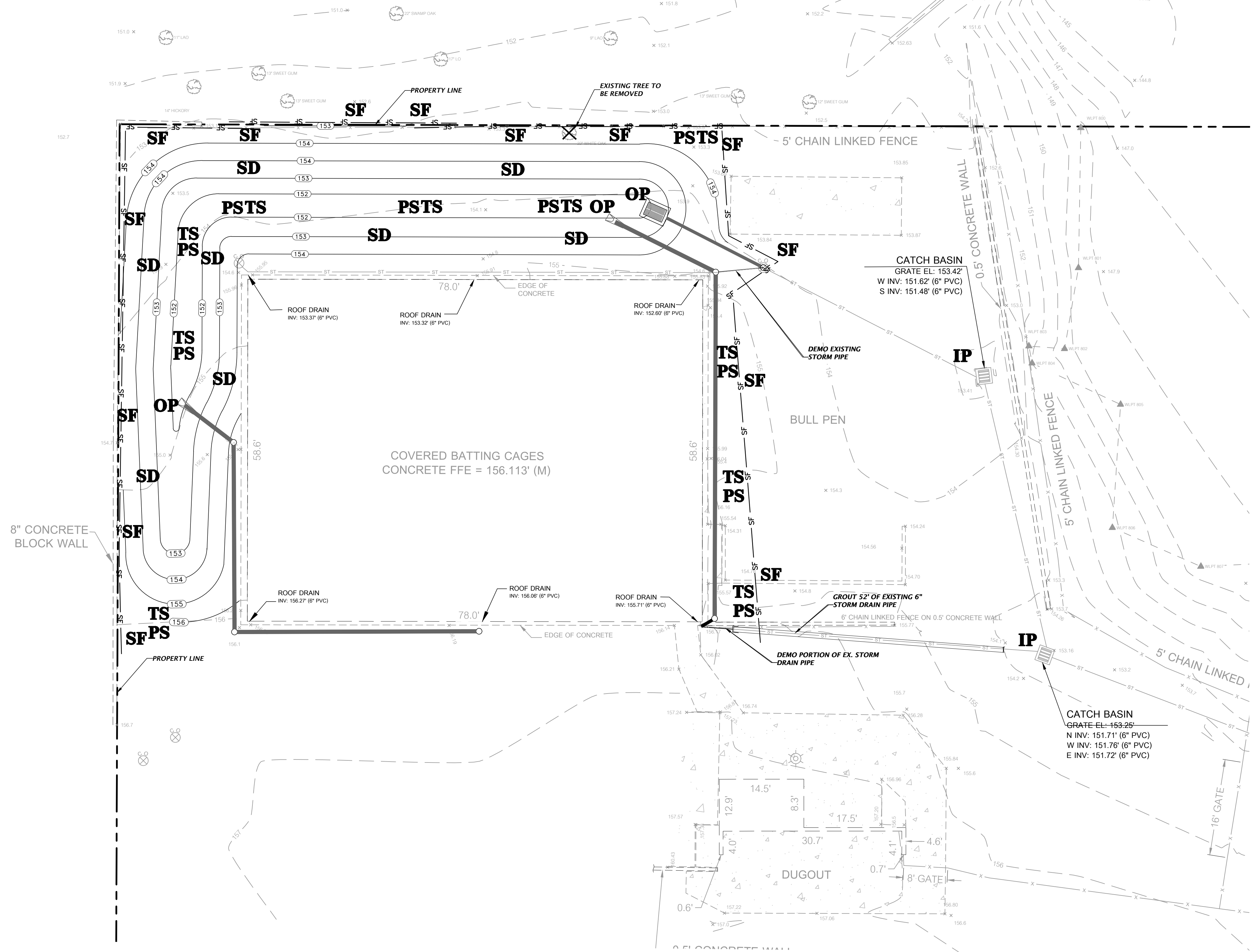
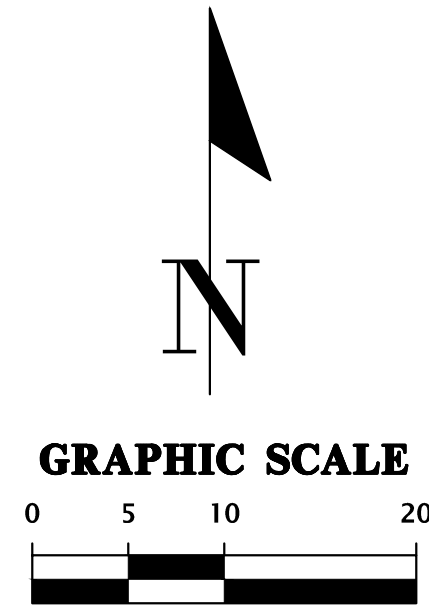
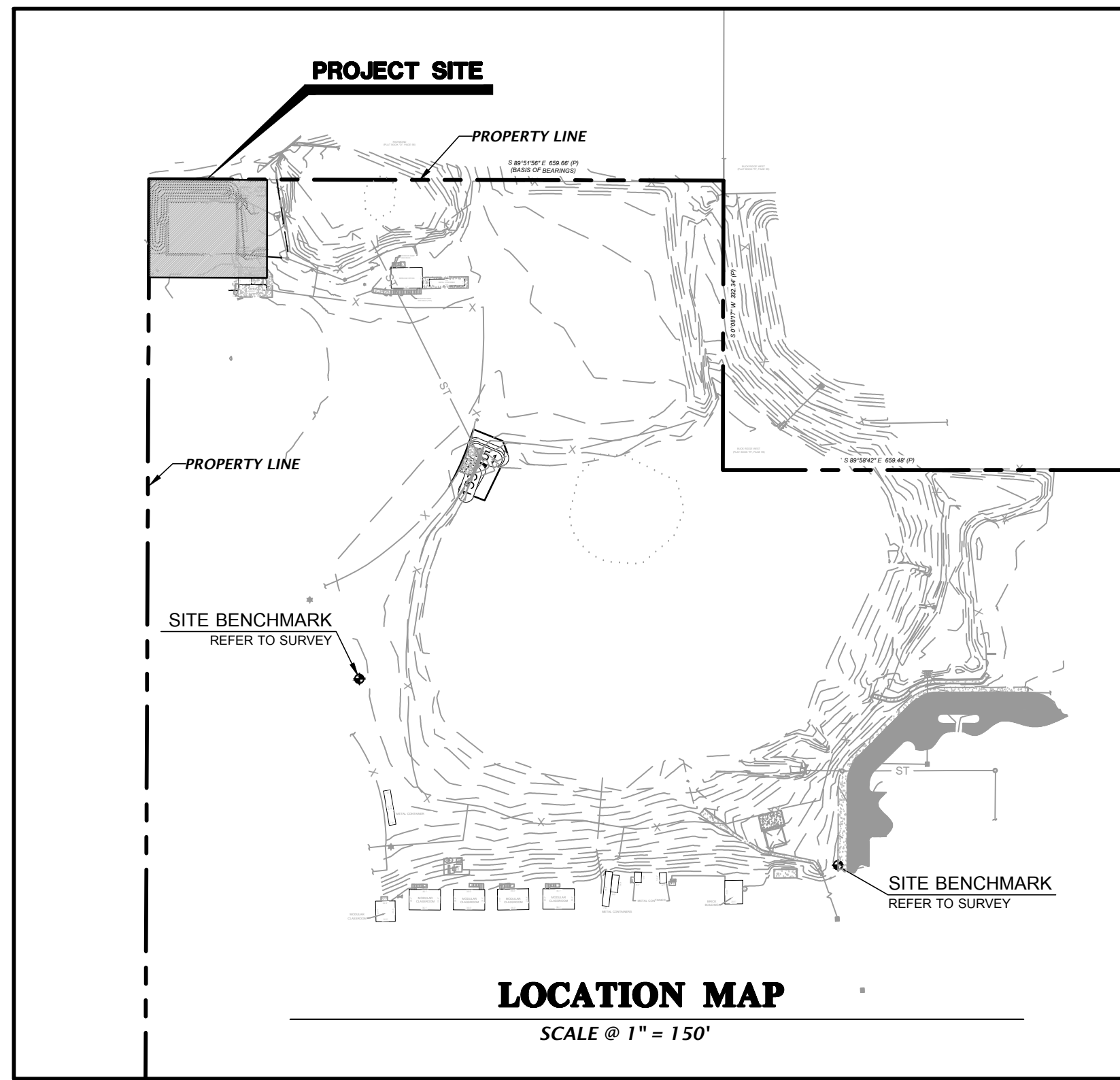

EROSION & SEDIMENTATION CONTROL

1. SILT FENCING AND/OR STAKED HAYBALES SHALL BE CONSTRUCTED WHERE SHOWN ON THE DRAWINGS PRIOR TO STARTING CONSTRUCTION.
2. ALL STORMDRAIN INLETS SHALL BE PROTECTED DURING CONSTRUCTION IN ACCORDANCE WITH FDOT STATE OF FLORIDA EROSION AND SEDIMENT CONTROL DESIGNER AND REVIEWER MANUAL.
3. THE STORMDRAIN SYSTEM SHALL BE FLUSHED OUT TO REMOVE ALL ACCUMULATED DEBRIS AND SEDIMENT UPON COMPLETION OF CONSTRUCTION.
4. ALL DISTURBED AREAS IN THE CONSTRUCTION AREA SHALL BE COMPLETELY STABILIZED BY COMPLETION OF CONSTRUCTION. GRASS SEEDING RATES AND MIXTURES SHALL BE PER SECTION 570 OF THE STANDARD SPECIFICATIONS. EVIDENCE OF GROWTH MUST BE PRESENT PRIOR TO FINAL RELEASE.

LEGEND

SEE SHEET C2.30 FOR DETAILS

- TS** = TEMPORARY SEEDING
- PS** = PERMANENT SEEDING
- SD** = SOD STABILIZATION
- SF** = SILT BARRIER (SEE DETAIL HEREON)
- IP** = INLET PROTECTION
- OP** = OUTLET PROTECTION
- CO** = CONSTRUCTION ENTRANCE/EXIT
- TB** = TURBIDITY BARRIER

11801 Research Drive Alachua, Florida 32615 (352) 331-1976 www.ch2m.com est. 1988 FLORIDA CA-5075	
SCALE: 1" = 10' VERIFY ALL DIMENSIONS ON ORIGINAL DRAWING IF ANY DISCREPANCY, THIS SHEET ADJUST SCALES ACCORDINGLY.	CONSTRUCTION AND PROVISIONS
CLIENT: ALACHUA COUNTY PUBLIC SCHOOLS PROJECT: RICHARDZ HIGH SCHOOL BATTING CAGE DRAINAGE SHEET TITLE: DEMOLITION AND STORMWATER POLLUTION PREVENTION PLAN	
DESIGNER: K.T. McMAHON CHECKER: G. LEDFORD, E.I. QUALITY CONTROL: W. OWEN, P.E. PROJECT NUMBER: 22-0241	
WALKER FAIN OWEN, PE	
FL PE No. 94201 SHEET NO. C0.20	

Title: gabriel.dwg Plot Date: Apr 08, 2024 11:51am File: N:\2022\22-0241\Department\CA_Engineering\02_DWG-BattlingCage\Production\Plan\22-0241-SWP_Pollit and Dem.dwg

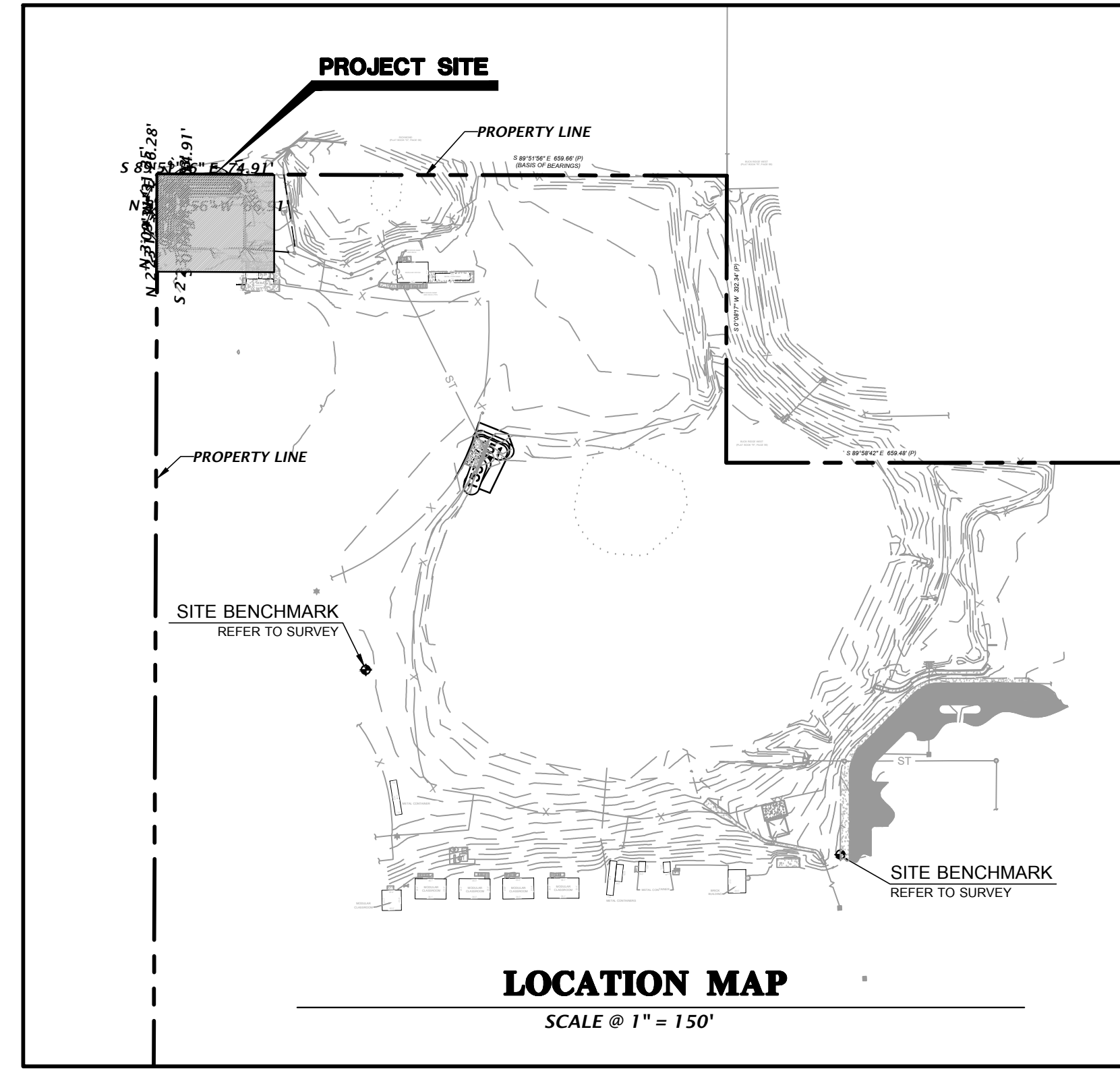

LOCATION MAP
SCALE @ 1" = 150'

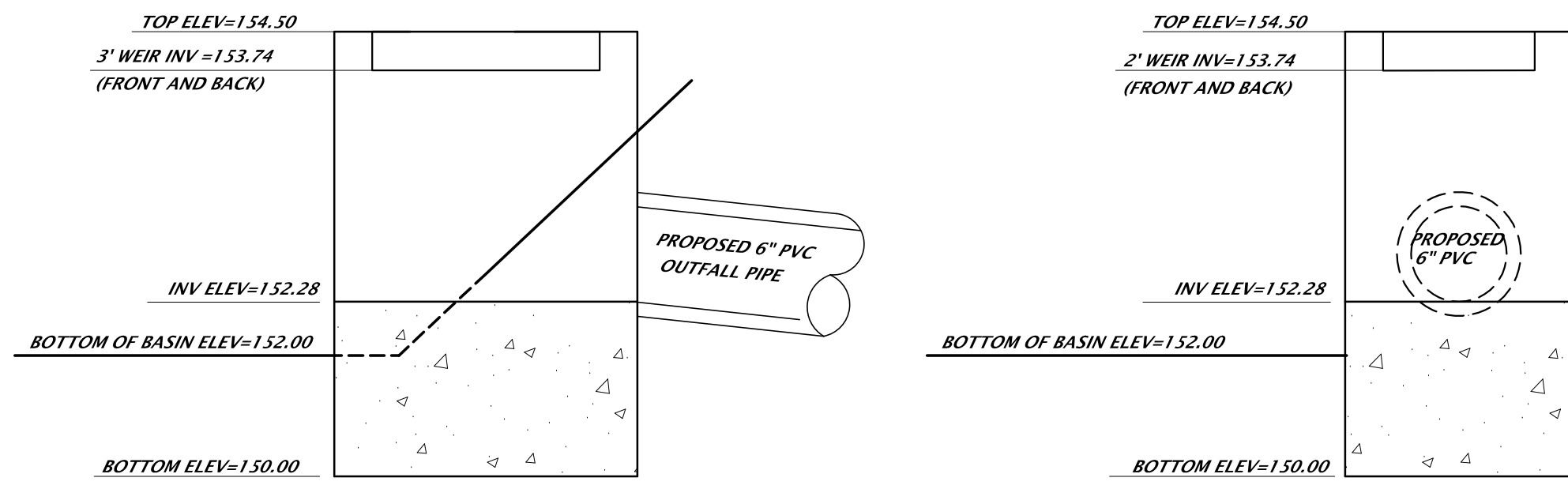
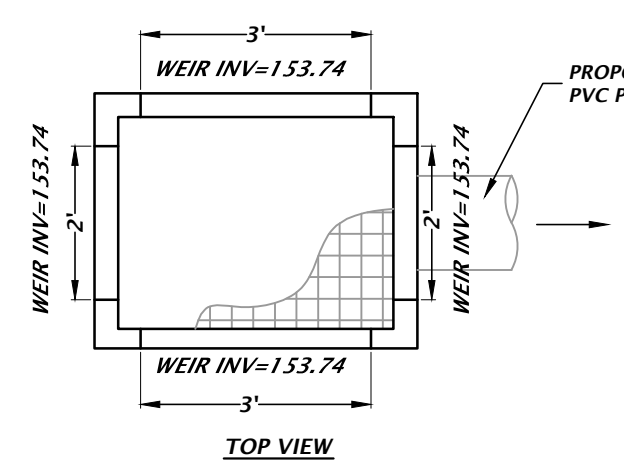
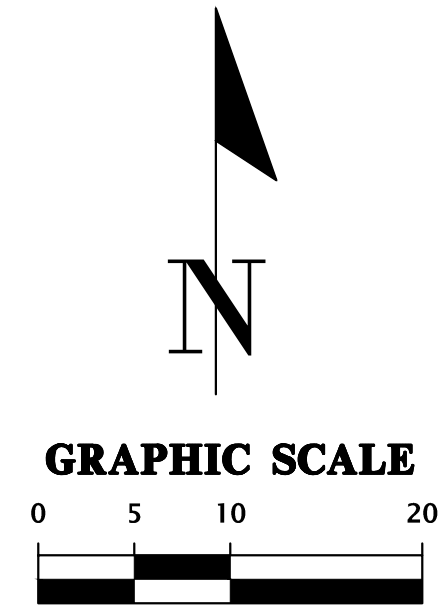

OUTFALL STRUCTURE TYPE 'C' INLET
NTS

EARTHEN BERM SHALL BE CONSTRUCTED WITH SOILS WITH A MINIMUM OF 15% SOIL FINES PASSING NO. 200 SIEVE. COMPACT BERM TO 95% MAXIMUM DENSITY PER AASHTO METHOD T-99 WITH MAXIMUM 12" LIFTS. FOOT A-3 SAND OR ANY OTHER HIGHLY PERMEABLE MATERIAL SHALL NOT BE USED.

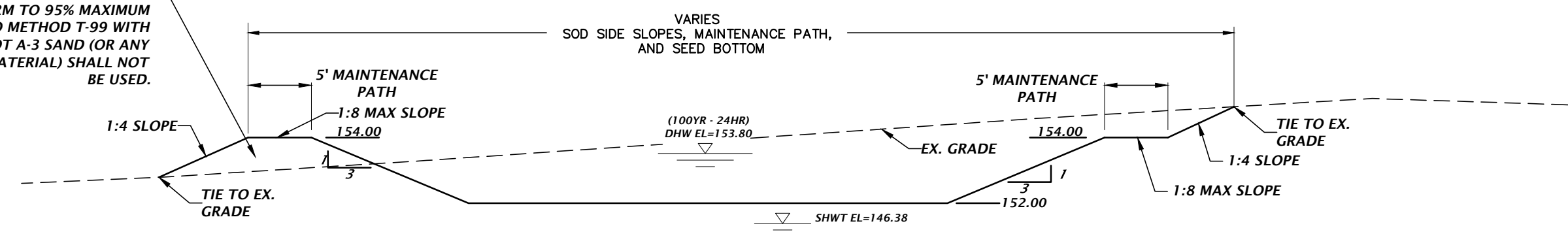

- IF A CONTINUOUS LIMEROCK FORMATION IS ENCOUNTERED IN THE BASIN AREA CONTACT THE ENGINEER OF RECORD. THE LIMEROCK SHALL BE EXCAVATED TO A MINIMUM DEPTH OF 3 FEET BEYOND THE BASIN UNDERCUT LIMITS.
- IF A SOLUTION PIPE SINKHOLE DOES FORM IN THE STORMWATER BASIN, THEN THE SINKHOLE SHALL BE REPAIRED BY BACKFILLING WITH MATERIAL OF LOWER PERMEABILITY MATERIAL, SUCH AS CLAYEY SAND OR CLAY. THE MATERIAL SHALL BE COMPACTED AND THE SINKHOLE REPAIR SHOULD BRING THE SURFACE BACK TO AN ELEVATION WHICH IS SLIGHTLY ABOVE THE ORIGINAL BOTTOM, CREATING A SMALL MOUND.

STORMWATER MANAGEMENT FACILITY
CROSS SECTION A-A

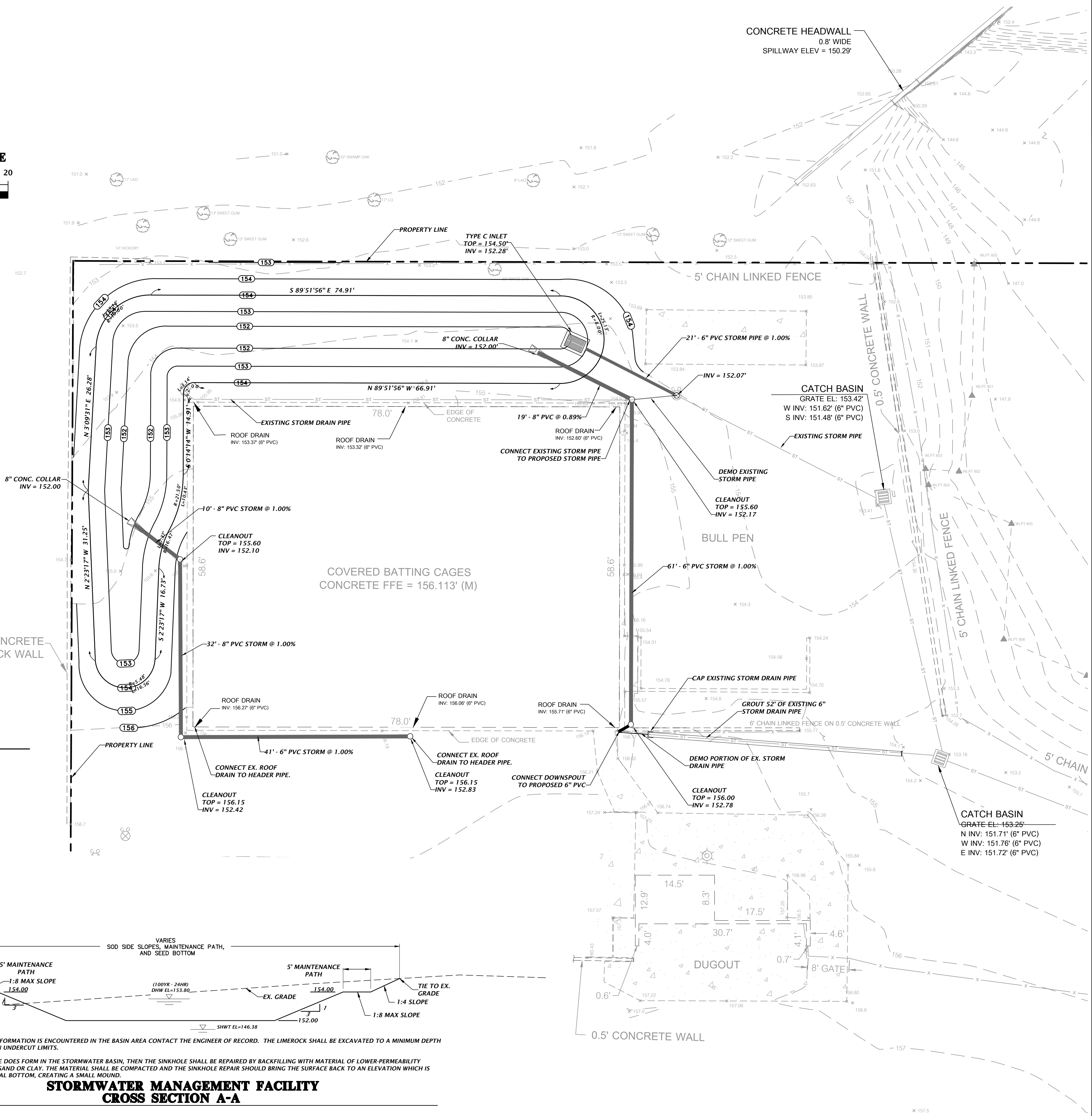

11801 Research Drive
Alachua, Florida 32615
(352) 331-1976
www.chw-inc.com
est. 1988 FLORIDA
CA-5075

CHW
Professional Consultants

SCALE: 1" = 10'
VERIFY ALL DATA ON ORIGINAL DRAWING
IF ANY DISCREPANCIES ARE FOUND ON THIS SHEET, ADJUST SCALES ACCORDINGLY.

CONSTRUCTION AND RECORDS

CLIENT: ALACHUA COUNTY PUBLIC SCHOOLS
PROJECT: RICHMOND HIGH SCHOOL BATTING CAGE DRAINAGE
SHEET TITLE: DETAILED GRADING AND DRAINAGE

DATE: 02/20/2024 SHRMW
04/08/2024 BID DOCUMENTS, SCHOOL BOARD OF ALACHUA COUNTY

DESIGNER: K.T. MCMAHON
CHECKER: G. LEFORD, E.I.
QUALITY CONTROL: W. OWEN, P.E.
PROJECT NUMBER: 22-0241

WALKER FAIR OWEN, PE

FL PE No. 94201
SHEET NO. **C2.00**

Title: gabriel.dwg Plot Date: Apr 08, 2024 11:48am File Name: N:\2024\22-0241\Department\GA_Engineering\02_DWG-BattlingCage\Production\24x32-0241-000.dwg

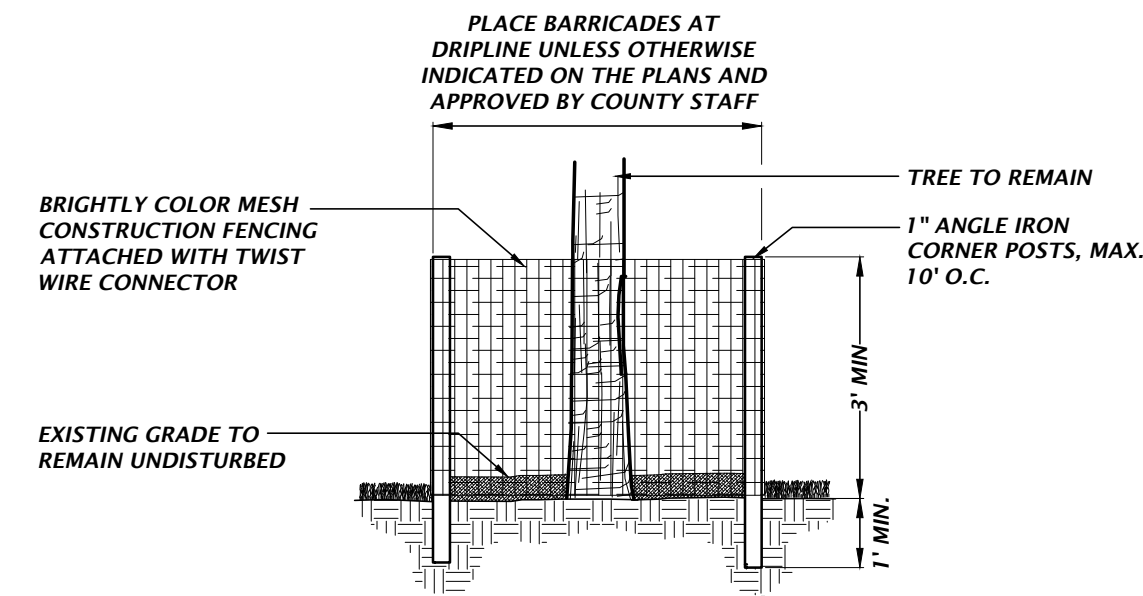

TREE PROTECTION DETAIL

NTS

NOTE:

- PROTECTIVE BARRIERS SHALL BE CONSTRUCTED, AS NECESSARY, TO PREVENT THE DESTRUCTION OR DAMAGING OF REGULATED TREES THAT ARE LOCATED WITHIN 50 FEET OF ANY CONSTRUCTION ACTIVITY OR STORAGE OF EQUIPMENT AND MATERIALS.
- PROTECTIVE BARRIERS SHALL BE PLAINLY VISIBLE AND SHALL CREATE A CONTINUOUS BOUNDARY AROUND TREES OR VEGETATION CLUSTERS IN ORDER TO PREVENT ENCROACHMENT BY MACHINERY, VEHICLES OR STORED MATERIALS.
- TREE BARRICADES MUST BE INSPECTED AND APPROVED BY COUNTY STAFF. PRIOR TO ANY CLEARING, DEMOLITION, OR GRUBBING WORK BEGINS, CONTACT GROWTH MANAGEMENT, 352-374-3249.
- PROTECTIVE BARRIERS SHALL REMAIN IN PLACE AND INTACT UNTIL SUCH TIME AS LANDSCAPE OPERATIONS BEGIN.
- ALL CONSTRUCTION ACTIVITIES SHALL BE PROHIBITED WITHIN THE UNDISTURBED AREA INCLUDING ALL DIGGING, TRENCHING, CONSTRUCTION LAY-DOWN AREAS, PLACEMENT OF HAZARDOUS MATERIALS, INCLUDING FUELS AND SOLVENTS, PLACEMENT OF FILL OR SOILS, AND PARKING OF VEHICLES.
- NO ATTACHMENT OR WIRES SHALL BE ATTACHED TO ANY TREE.
- NO GRADE CHANGES SHALL BE MADE WITHIN ANY UNDISTURBED AREA WITHOUT PRIOR APPROVAL BY THE COUNTY INSPECTOR. IF A GRADE CHANGE IS MADE AND ROOTS LARGER THAN ONE INCH IN DIAMETER ARE DAMAGED OR EXPOSED, THEY SHALL BE CUT CLEANLY AND RECOVERED WITH SOIL.

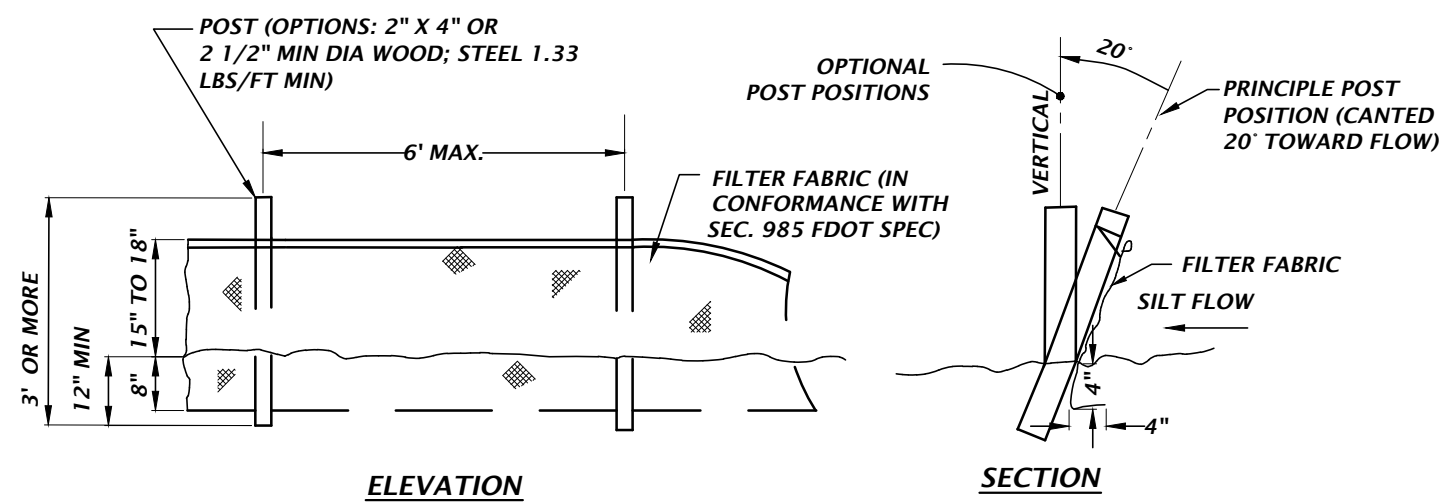

TYPE III SILT FENCE DETAIL

NTS

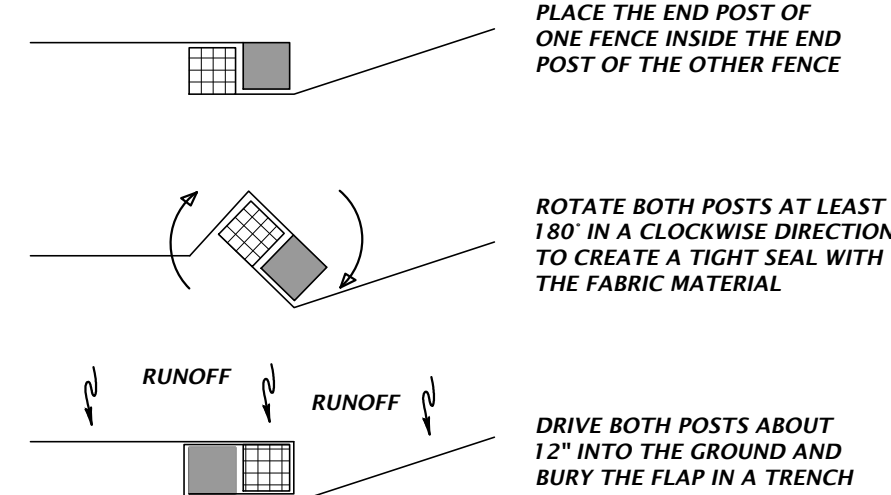

FOR ATTACHING TWO SILT FENCES WHEN TRENCHING IS USED

TYPE III SILT FENCE WRAPPING DETAIL

NTS

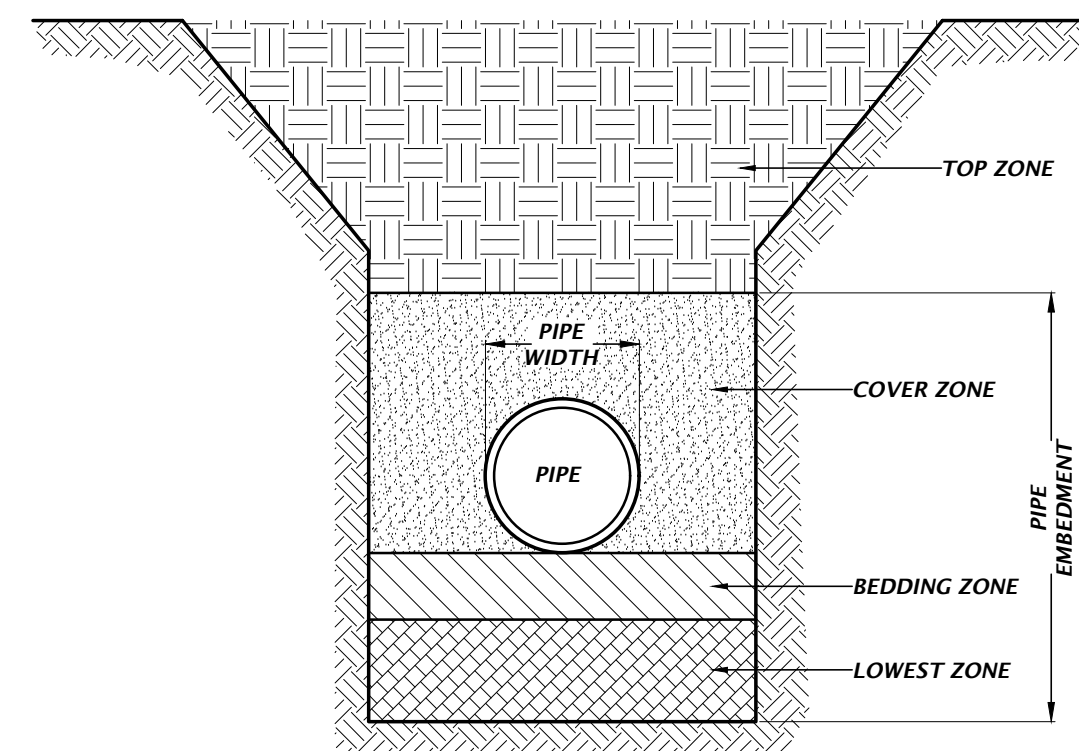

- STORM PIPE BEDDING AND BACKFILL SHALL BE PER FDOT SPECIFICATION 125-8 AND 125-9.
- SOIL/MATERIAL TYPES ARE AS DETERMINED PER AASHTO M145 SOIL CLASSIFICATIONS AND ASTM D3282.
- DO NOT ALLOW HEAVY CONSTRUCTION EQUIPMENT TO CROSS OVER CULVERT OR STORM SEWER PIPES UNTIL PLACING AND COMPACTING BACKFILL MATERIAL TO THE FINISHED EARTHWORK GRADE OR TO AN ELEVATION AT LEAST FOUR (4) FEET ABOVE THE CROWN OF THE PIPE.
- THE LOWEST ZONE IS BACKFILLED FOR DEEP UNDERCUTS UP TO WITHIN FOUR (4) INCHES OF THE BOTTOM OF THE PIPE. BACKFILL IN THIS ZONE SHALL BE COARSE SAND, OR OTHER SUITABLE GRANULAR MATERIAL, OBTAINED FROM THE GRADING OPERATIONS ON THE PROJECT, OR A COMMERCIAL MATERIAL (AS APPROVED BY THE ENGINEER OF RECORD) IF NO SUITABLE MATERIAL IS AVAILABLE. COMPACT THE SOIL TO APPROXIMATELY MATCH THE DENSITY OF THE SOIL IN WHICH THE TRENCH WAS CUT.
- THE BEDDING ZONE IS ABOVE THE LOWEST ZONE AND USUALLY WILL BE THE BACKFILL WHICH IS THE FOUR (4) INCHES OF SOIL BELOW THE BOTTOM OF THE PIPE. WHEN ROCK OR OTHER HARD MATERIAL HAS BEEN REMOVED TO PLACE THE PIPE, THE BEDDING ZONE WILL BE THE TWELVE (12) INCHES OF SOIL BELOW THE BOTTOM OF THE PIPE. THE BACKFILL MATERIAL TO BE USED SHALL BE CLASSIFIED AS A-1, A-2, OR A-3. MATERIAL CLASSIFIED AS A-4 MAY BE USED IF THE PIPE IS CONCRETE PIPE. PLACE MATERIAL IN LIFTS NO GREATER THAN SIX (6) INCHES (COMPACTED THICKNESS).
- THE COVER ZONE IS BACKFILL THAT IS PLACED AFTER THE PIPE HAS BEEN LAID AND EXTENDS TWELVE (12) INCHES ABOVE THE TOP OF THE PIPE. THE BACKFILL MATERIAL TO BE USED SHALL BE CLASSIFIED AS A-1, A-2, OR A-3. MATERIAL CLASSIFIED AS A-4 MAY BE USED IF THE PIPE IS CONCRETE PIPE. PLACE MATERIAL IN LIFTS NO GREATER THAN SIX (6) INCHES (COMPACTED THICKNESS), EVENLY DEPOSITED ON BOTH SIDES OF THE PIPE AND COMPACT WITH MECHANICAL TAMPERS SUITABLE FOR THIS PURPOSE. HAND TAMP MATERIAL BELOW THE PIPE HAUNCH THAT CANNOT BE REACHED BY MECHANICAL TAMPERS.
- THE TOP ZONE EXTENDS FROM TWELVE (12) INCHES ABOVE THE TOP OF THE PIPE TO THE BASE OR FINAL GRADE. BACKFILL WITH MATERIALS ALLOWED PER FDOT INDEX NO. 505. PLACE MATERIAL IN LAYERS NOT TO EXCEED TWELVE (12) INCHES IN COMPACTED THICKNESS.
- MINIMUM ACCEPTABLE COMPACTION FOR THE BEDDING, COVER, AND TOP ZONES IS 100% OF THE STANDARD PROCTOR MAXIMUM DENSITY AS DETERMINED BY AASHTO T-99, METHOD C. FOR METAL OR PLASTIC PIPE, COMPACT THE BACKFILL TO A DENSITY OF AT LEAST 95% OF THE STANDARD PROCTOR AS DETERMINED BY AASHTO T-99, METHOD C.
- WHEN INSTALLING HDPE PIPE, BEDDING, BACKFILL, AND GENERAL INSTALLATION REQUIREMENTS SHALL COMPLY WITH ASTM D2321.

STORM PIPE BEDDING AND BACKFILLING DETAIL

NTS

TYPICAL INSTALLATION SEQUENCE FOR SILT-SAVER FRAME AND FILTER

- EXCAVATE APPROXIMATELY 4" TO 6" BELOW THE TOP OF THE INLET STRUCTURE.
- PLACE THE FRAME ONTO THE INLET STRUCTURE, ENSURING PROPER SEATING OF FRAME TO STRUCTURE.
- SLIDE THE FILTER OVER THE FRAME.
- FILL THE FILTER POCKETS WITH SOIL, #57 GRAVEL OR EQUIVALENT. THE FILTER POCKETS SHOULD BE COMPLETELY FILLED TO ENSURE A GOOD SEAL BETWEEN THE GROUND AND INLET STRUCTURE.
- BACK FILL AROUND THE FRAME AND FILTER ASSEMBLY IS NOT REQUIRED TO COMPLETE INSTALLATION; HOWEVER, BACK FILLING MAY BE NECESSARY TO COMPLETE EXCAVATION REQUIREMENTS FOR THE SITE.

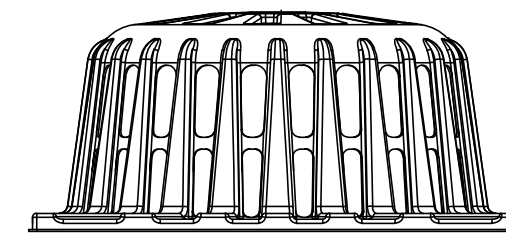
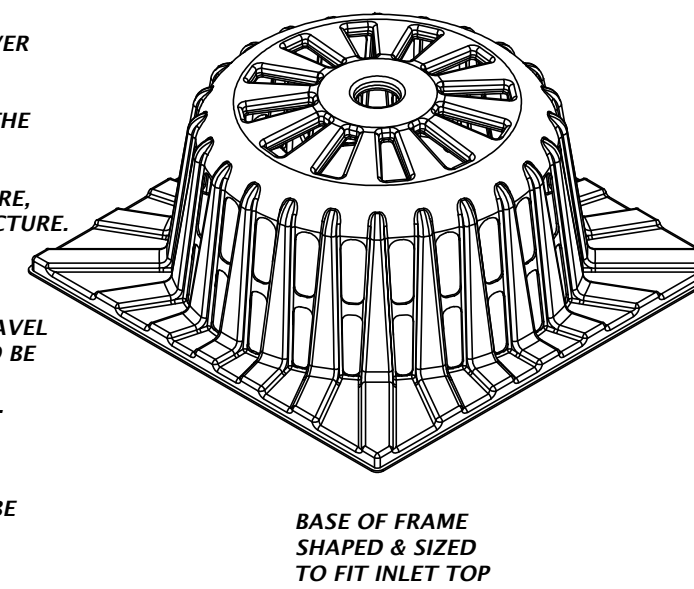

SILT-SAVER® DETAIL

NTS

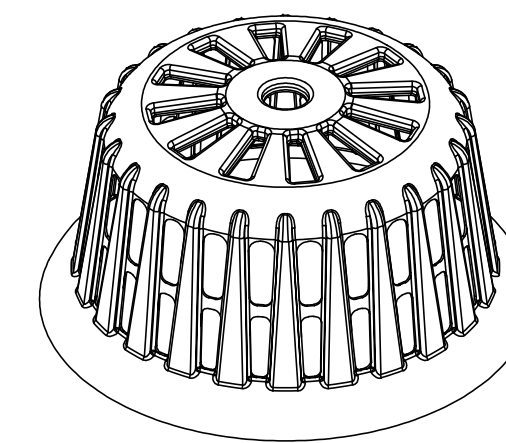

INLET PROTECTION OPTIONS DETAIL

NTS

- CONSTRUCTION EXIT INSTALLATION SHALL REMOVE MUD/SOILS FROM TIRES TO PREVENT TRACKING ONTO PUBLIC ROADS.
- TOP DRESSING WITH 2" STONE MAY BE REQ'D AS DETERMINED BY THE USE AND FUNCTION OF THE SYSTEM.
- THE WASH PIT SHOULD BE INSTALLED IF THE STANDARD CONSTRUCTION EXIT DOES NOT SUFFICIENTLY REMOVE SOILS AND WASHING IS REQ'D.

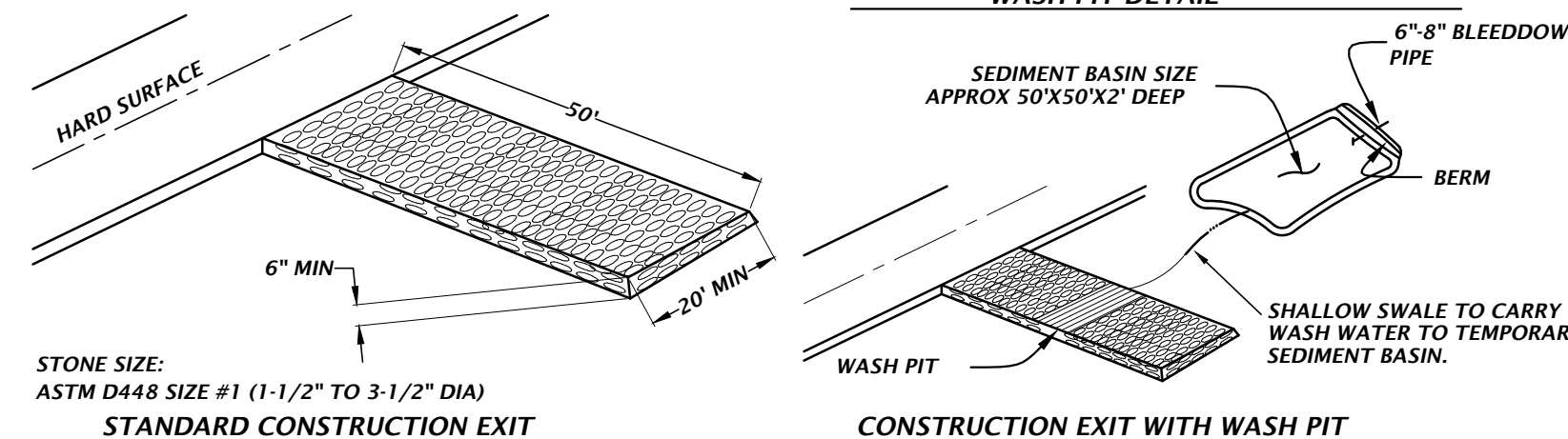
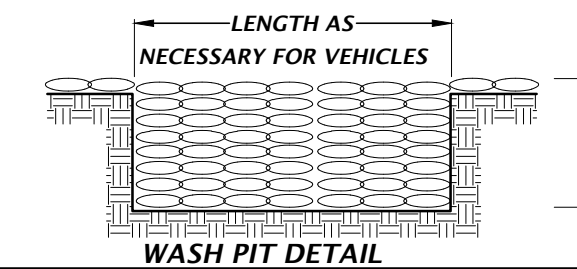

TEMPORARY CONSTRUCTION EXIT DETAIL

NTS

BASIN EROSION & SEDIMENTATION CONTROL

- SILT FENCING AND/OR STAKED HAYBALES SHALL BE CONSTRUCTED WHERE SHOWN ON THE DRAWINGS PRIOR TO STARTING CONSTRUCTION.
- ALL STORMDRAIN INLETS SHALL BE PROTECTED DURING CONSTRUCTION IN ACCORDANCE WITH FDOT STATE OF FLORIDA EROSION AND SEDIMENT CONTROL DESIGNER AND REVIEWER MANUAL.
- THE DRAINAGE BASINS SHALL BE ROUGH GRADED PRIOR TO CONSTRUCTING THE LIMEROCK BASE. THE RETENTION BASINS SHALL BE FINE GRADED AND GRASSED PRIOR TO PAVING AND SITE CLEANUP.
- THE STORMDRAIN SYSTEM SHALL BE FLUSHED OUT TO REMOVE ALL ACCUMULATED DEBRIS AND SEDIMENT UPON COMPLETION OF CONSTRUCTION.
- THE DRAINAGE BASIN BOTTOM SHALL BE SCRAPED CLEAN OF ALL ACCUMULATED SEDIMENT UPON COMPLETION OF CONSTRUCTION AFTER THE STORMDRAIN SYSTEM IS COMPLETELY FLUSHED OUT. THIS ACTIVITY SHALL ONLY OCCUR IN A DRY STATE.
- ALL DISTURBED AREAS IN THE CONSTRUCTION AREA SHALL BE COMPLETELY STABILIZED BY COMPLETION OF CONSTRUCTION. GRASS SEEDING RATES AND MIXTURES SHALL BE PER SECTION 570 OF THE STANDARD SPECIFICATIONS. EVIDENCE OF GROWTH MUST BE PRESENT PRIOR TO FINAL RELEASE.
- REFER TO THE SWPPP PLAN FOR COMPLETE EROSION CONTROL MEASURES.
- WHERE POND TOP OF BANK IS IN CUT TO EXISTING GRADE, CONTRACTOR SHALL SOD 5-FT BEYOND TOP OF BANK FOR EROSION PROTECTION.

STORMWATER POLLUTION PREVENTION LEGEND

- TS = TEMPORARY SEEDING
- PS = PERMANENT SEEDING
- ML = MULCHING
- SD = SOD STABILIZATION
- SE = SILT BARRIER
- TB = TREE BARRIER
- IP = INLET PROTECTION
- OP = OUTLET PROTECTION
- CO = CONSTRUCTION ENTRANCE/EXIT

DANDY SACK™ DETAIL

NTS

INSTALLATION:
REMOVE THE GRATE FROM INLET. IF USING OPTIONAL OIL ABSORBENTS, PLACE ABSORBENT PILLOW IN UNIT. STAND THE GRATE ON END. MOVE THE TOP LIFTING STRAPS OUT OF THE WAY AND PLACE THE GRATE INTO THE DANDY SACK™ SO THAT THE GRATE IS BELOW THE TOP STRAPS AND ABOVE THE LOWER STRAPS. HOLDING THE LIFTING DEVICES, INSERT THE GRATE INTO THE INLET.

MAINTENANCE:
REMOVE ALL ACCUMULATED SEDIMENT AND DEBRIS FROM VICINITY OF UNIT AFTER EACH STORM EVENT. AFTER EACH STORM EVENT AND AT REGULAR INTERVALS, LOOK INTO THE DANDY SACK™. IF THE CONTAINMENT AREA IS MORE THAN 1/3 FULL OF SEDIMENT, THE UNIT MUST BE EMPTIED. TO EMPTY UNIT, LIFT THE UNIT OUT OF THE INLET USING THE LIFTING STRAPS AND REMOVE THE GRATE. IF USING OPTIONAL OIL ABSORBENTS, REPLACE ABSORBENT WHEN NEAR SATURATION.

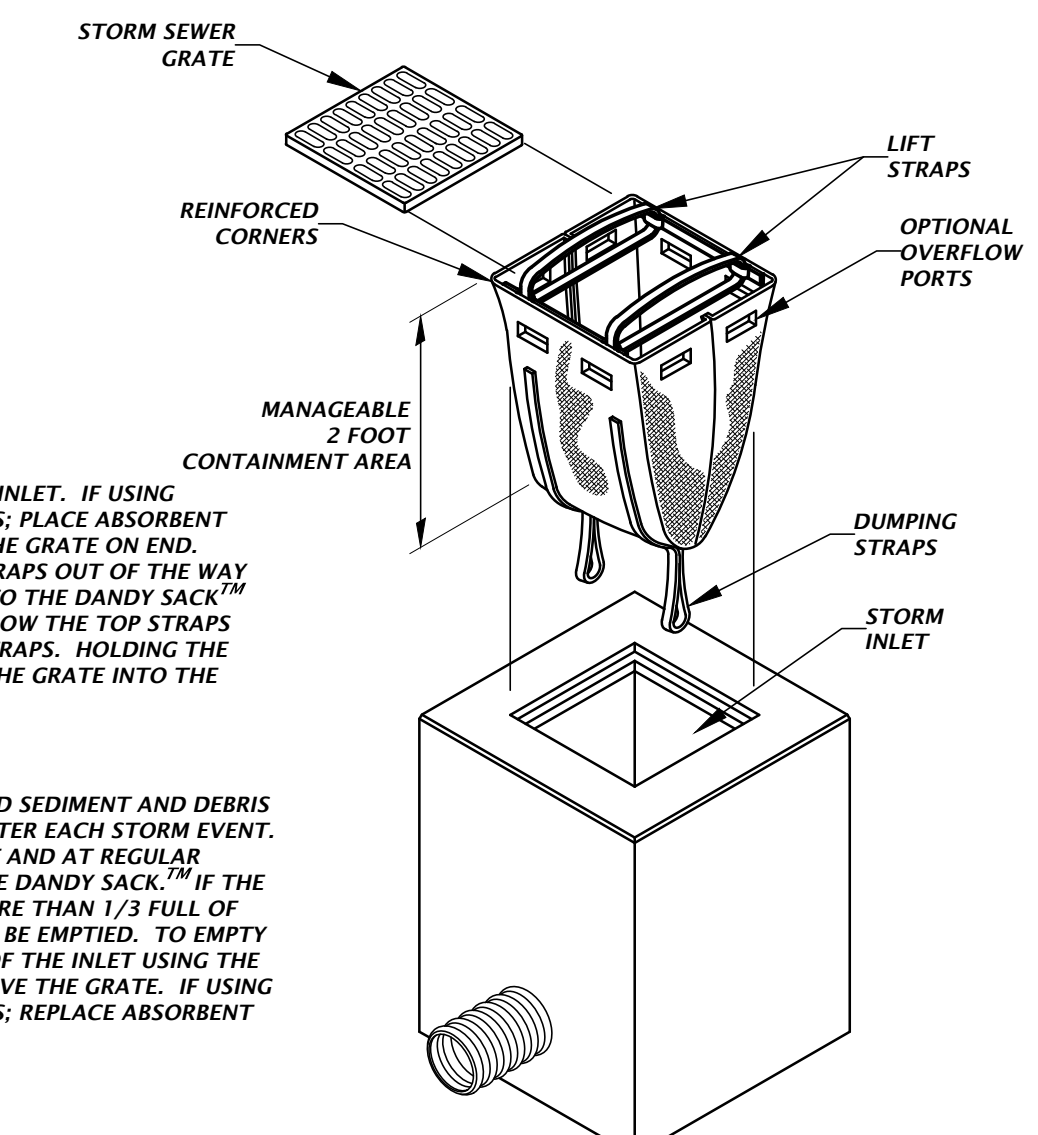

11801 Research Drive
Alachua, Florida 32615
(352) 351-1976
www.chw-inc.com
est. 1988 FLORIDA
CA-5075

CHW
Professional Consultants

VERIFY SCALE ON ORIGINAL DRAWING
IF SHOWN IN THIS SHEET, ADJUST SCALES ACCORDINGLY.

SCALE: 1"=20'

CONSTRUCTION AND REVISIONS

02/27/2024 SHIRMO
04/08/2024 BID DOCUMENTS, SCHOOL BOARD OF ALACHUA COUNTY

CLIENT: ALACHUA COUNTY PUBLIC SCHOOLS
PROJECT: BIGHUS F. JENY SENIOR BATTING CAGE DRAINAGE

DESIGNER: K.T. MCMAHON
CHECKER: G. LEFORD, E.I.
QUALITY CONTROL: W. OWEN, P.E.
PROJECT NUMBER: 22-0241

WALKER FAIN OWEN, PE

FL PE No. 94201

SHEET NO.

C2.30

File Name: N:\2022\22-0241\Department\CA_Engineering\02_DWG-BattlingCage\Production\Plan\22-0241-Cont\Detail.dwg
Title: gpb1001
Plot Date: Apr 08, 2024 11:15:40am